

Math 331 - Ordinary Differential Equations

September 29, 2020

## Introduction to Differential Equations

### Mathematical Models and Direction Fields

- Introduction to Mathematical Models
- Equilibrium Solutions
- Pond Example

### Solutions of Differential Equations

- Introduction to Solutions to Differential Equations
- Revisit Falling Object
- Population Model
- Population Model with Initial Condition

### Types of Differential Equations

## First-Order Differential Equations

### Linear Ordinary Differential Equations

- Introduction to Linear Differential Equations
- Linear Differential Equations - Example 1
- Linear Differential Equations - Example 2
- Linear Differential Equations - Example 3
- Linear Differential Equations - Application

### Separable Differential Equations

- Introduction to Separable Differential Equations
- Separable Differential Equations - Example 2
- Separable Differential Equations - Example 3
- Homogeneous Differential Equations - Example

### Modeling with Differential Equations - Revisited

- Revisiting Mathematical Modeling
- Revisiting Mathematical Modeling - Bank Example
- Revisiting Mathematical Modeling - Tank Example

### Autonomous Differential Equations

- Introduction to Autonomous Differential Equations
- Autonomous Differential Equations - Example
- Autonomous Differential Equations - Semi-Stable Example

### Existence and Uniqueness of Solutions

- Existence and Uniqueness of Solutions - Nonexample

### Euler's Method

### Exact Equations

- Introduction to Exact Equations
- Exact Equations - Example

## Second-Order Differential Equations

### Introduction to Second-Order Differential Equations

- Homogeneous Differential Equations
- Homogeneous Differential Equations - Example
- Homogeneous Differential Equations - Example 2
- Homogeneous Differential Equations - Example 3

### Wronskian Determinant

- Existence and Uniqueness Theorem for Second-order, linear diff. eq.
- Existence and Uniqueness Theorem - Example
- Families of Solutions vs. General Solution
- General Solutions of Second-Order Linear Homog. Diff. Eq.
- Wronskian Determinant for General Solutions with Exponentials
- Wronskian Determinant for General Solutions with Exponentials - Example
- Abel's Theorem

### Complex Roots to Characteristic Equations

- Introduction to Char. Eq. with Complex Roots
- Char. Eq. with Complex Roots - Example
- Char. Eq. with Complex Roots - Example

### Repeated Roots to Characteristic Equations

- Introduction to Char. Eq. with Repeated Roots
- Computing a Second Solution for Repeated Roots
- Wronskian for Char. Eq. with Repeated Roots
- Char. Eq. with Repeated Roots - Example

### Nonhomogeneous Differential Equations

- Introduction to Nonhomogeneous Differential Equations
- Particular Solutions to Nonhomogeneous Differential Equations
- Nonhomogeneous Differential Equation - IVP example
- Particular Solutions to Nonhomogeneous Differential Equations - sine example
- Particular Solutions to Nonhomogeneous Differential Equations - Polynomial example
- Particular Solutions to Nonhomogeneous Differential Equations - second guess ex
- Particular Solutions to Nonhomogeneous Differential Equations - third guess ex
- Particular Solutions to Nonhomogeneous Differential Equations - sum example

### Mechanical Vibrations

- Introduction to Mechanical Vibrations
- Undamped Mechanical Vibrations
- Undamped Mechanical Vibrations - Example
- Mechanical Vibrations - Example
- Mechanical Vibrations - Damping Analysis

### Forced Mechanical Vibrations

- Introduction to Forced Mechanical Vibrations
- Forced Mechanical Vibrations - Resonance

## Laplace Transforms

### Introduction to Laplace Transforms

- Definition of Laplace Transforms
- Laplace Transform of  $y(t) = 1$
- Laplace Transform of  $y(t) = e^{at}$
- Laplace Transform of  $y(t) = t$
- Laplace Transform of  $y(t) = \sin(\alpha t)$
- Laplace Transform of piecewise function,  $y(t)$
- Linearity of Laplace Transforms
- Linearity of Laplace Transforms - example

### Solutions to IVP's using Laplace Transforms

- Laplace Transform of  $\frac{dy}{dt}$
- Solving a Diff. Eq. with Laplace Transforms - Example
- Process for Solving a Diff. Eq. with Laplace Transforms
- Solving a Higher Order Diff. Eq. with Laplace Transforms
- Laplace Transform of  $y(t) = \cos(\alpha t)$
- Solving Second Order Diff. Eq. with Laplace Transforms - Example 1
- Solving Second Order Diff. Eq. with Laplace Transforms - Example 2

### Step Functions

- Definition of a Step Function
- Modifications of a Step Function
- Shifted Functions
- Laplace Transforms of Shifted Functions
- Laplace Transforms of Shifted Functions - Example
- Inverse Laplace Transforms of Shifted Functions - Example 1
- Inverse Laplace Transforms of Shifted Functions - Example 2
- Inverse Laplace Transforms of s-Shifted Functions
- Inverse Laplace Transforms of s-Shifted Functions - Example

### Solving Differential Equations with a Step Function

- Solving a Differential Equation with a Step Function - Example 1
- Solving a Differential Equation with a Step Function - Example 2

### Dirac Delta Functions

- Definition of a Dirac Delta Function
- Integral of a Dirac Delta Function
- Laplace Transform of a Dirac Delta Function
- Differential Equation w/ a Dirac Delta Function - Example

## Systems of Differential Equations

### Introduction to Systems of Differential Equations

- Linear Systems of Differential Equations
- Higher Order Systems of Differential Equations

### Matrices

- Matrices with Linear Systems of Differential Equations
- Operations of Matrices
- Self Operations of Matrices
- Inverse and Determinant
- Return to Linear Systems

### Systems of Linear Equations, Linear Independence, Eigenvalues, and Eigenvectors

- Phase Portrait
- Straight-Line Solutions
- Solutions of Linear Systems of Equations
- Eigenvalues and Eigenvectors
- Eigenvalues and Eigenvectors - Example

### Theory of Systems of First Order Linear ODEs

- Linearly Independent Vectors
- General Solutions of Linear Systems of Homogeneous Differential Equations

### Solutions of Linear Systems of Homogeneous Differential Equations

- Finding Solutions to Linear Systems of Differential Equations - Example
- Componentwise Solutions to Systems of Differential Equations
- Recap of Solutions to Systems of Diff Eq with distinct, real eigenvalues
- Solutions to Systems of Diff Eq with distinct, real eigenvalues - Example 2

[Phase Portrait for Systems - Example 2](#)  
[Phase Portrait for Systems - Example 1 Revisited](#)  
[Solutions to Systems of Diff Eq with distinct, real eigenvalues - Example 3](#)  
[Phase Portrait for Systems - Example 3](#)  
[Classifying Equilibrium Solutions for Linear Systems of Diff. Eq.](#)  
[Example 3 Revisited with an Initial Condition](#)

## Linear Systems with Complex Eigenvalues

[Solutions of Systems of Diff. Eq. - A Complex Example](#)  
[Solutions of Systems of Diff. Eq. - Complex Recap](#)  
[Classifying Equilibrium Solutions for Linear Systems of Diff. Eq. - Complex](#)

## Mathematical Models and Direction Fields

**Definition:** A **Differential Equation** is an equation that contains a derivative

**Definition:** A **Mathematical Model** is an equation that describes a physical application, along with the definitions of the variables used

**Example:** Suppose that an object is falling. The forces that we will consider to be acting on this object are gravity and air resistance.

**Example:** Suppose an object with mass  $m = 10$  and drag coefficient  $\gamma = 2$  is falling. Then our equation becomes

## Mathematical Models and Direction Fields

The plot of the slopes of  $v$  in the  $vt$ -plane when  $v = 40$ :

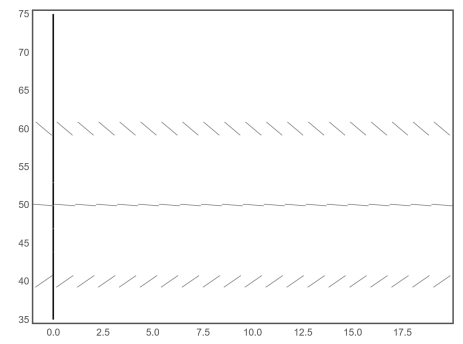
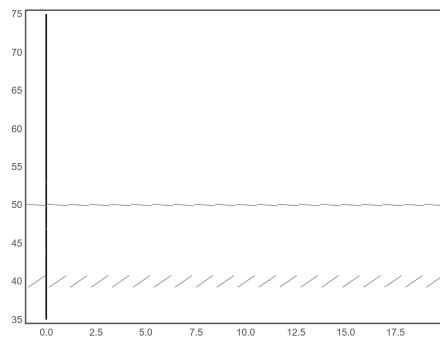
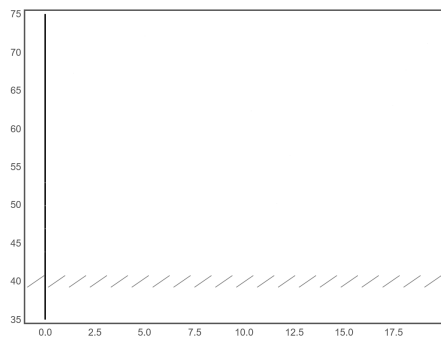

As we compute and plot  $\frac{dv}{dt}$  for more values of  $v$ , we get a fuller view of  $v(t)$

## Mathematical Models and Direction Fields

Let's look at the direction field with more vectors computed.

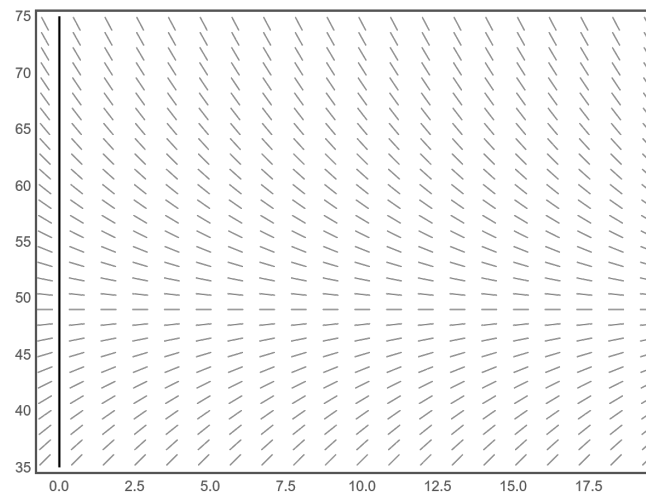

Notice that at one  $v$ -value, the tangent vectors are flat.

## Equilibrium Solutions of Differential Equations

**Example:** We modeled the velocity of a falling object with a Diff. Eq.

$$\frac{dv}{dt} = 9.8 - \frac{v}{5}$$

We haven't found formulas for solutions, but we learned a lot about the sol'ns.

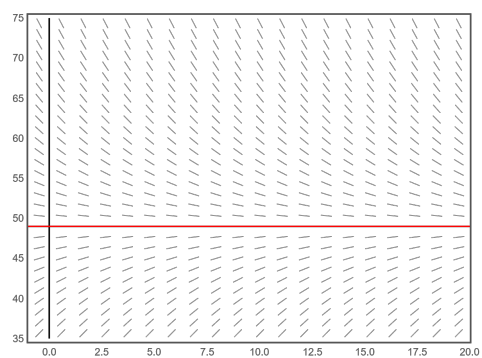



## Equilibrium Solutions of Differential Equations

**Example:** Find the equilibrium solution of

$$\frac{dy}{dt} = 2y - 6$$

and analyze the equilibrium solution to find  $\lim_{t \rightarrow \infty} y$

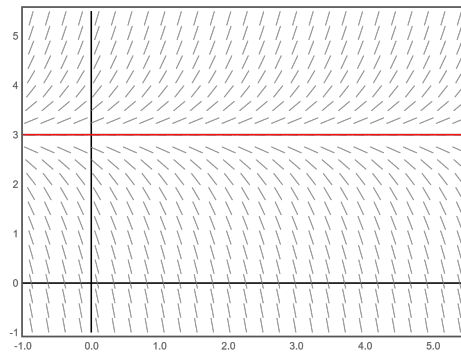

### Mathematical Models - Pond Example

**Example:** Consider a pond that holds  $10,000m^3$  of water that has one stream running into it and one running out. Water from Stream A flows in at  $500m^3/day$  while Stream B flows out at  $500m^3/day$ , so the amount of water stays constant. At time  $t = 0$  Stream A becomes contaminated with road salt at a concentration of  $5kg/1000m^3$ . Assume that the contaminant is evenly mixed throughout the pond.

Let  $S(t)$  be the amount of salt in the pond after  $t$  days of pollution, find  $S(t)$ .

## Mathematical Models - Pond Example

To find  $S(t)$ , we will need to solve the differential equation:

$$\frac{dS}{dt} = 2.5 - \frac{S}{20}$$

## Solutions of Differential Equations

In Calc 2, we studied equations of the form:

$$\frac{dv}{dt} = f(t) \quad \text{such as } \frac{dv}{dt} = 2t$$

and found the family of antiderivatives, such as  $v(t) = t^2 + c$  in the example.

While we didn't call it this at the time, these are differential equations.

In this course we will study differential equations of the form:

$$\frac{dv}{dt} = f(v, t)$$

That are functions of both the dependent and independent variable.

Since differential equations and integration are both rooted in the process of using information about a derivative to find information about the original function, integration will be involved in many of our techniques to solve differential equations.

Recall(Calc 2): The substitution rule says that:

$$\int f(v) \frac{dv}{dt} dt = \int f(v) dv$$

This will be key for our first method of solving differential equations

## Solutions of Differential Equations

Recall (Calc 2): The substitution rule says that:  $\int f(v) \frac{dv}{dt} dt = \int f(v) dv$

Example: Solve the Differential Equation  $\frac{dv}{dt} = v$

## Solutions of Differential Equations

Recall (Calc 2): The substitution rule says that:  $\int f(v) \frac{dv}{dt} dt = \int f(v) dv$

Example: Solve the Differential Equation  $\frac{dv}{dt} = v$

$$\ln|v| = t + C \quad \text{where } C = C_1 - C_2$$

So, we have reduced our problem of solving a differential equation down to solving an algebraic equation, for  $v$

Recall(Calc 2): The substitution rule says that:  $\int f(v) \frac{dv}{dt} dt = \int f(v) dv$

Example: Earlier, we modeled the velocity of a falling object with a Diff. Eq.

$$\frac{dv}{dt} = 9.8 - \frac{v}{5}$$

Find solutions for the velocity of the object,  $v(t)$

$$\int \frac{1}{49 - v} \frac{dv}{dt} dt = \int \frac{1}{5} dt$$



In a basic population model of a population,  $p(t)$ , the growth rate,  $\frac{dp}{dt}$ , is proportional to the population.

That is, it can be modeled by the diff. eq.:  $\frac{dp}{dt} = \gamma p$  for a constant  $\gamma$

**Example:** The population of Mice,  $p(t)$ , in a field  $t$  months after initial measurements are taken can be modeled by:

$$\frac{dp}{dt} = \frac{p}{2} - 450$$

Let's consider, further, that there are owls eating 450 mice per month.

This introduces a negative term in the differential equation model.

Find solutions for the population of mice,  $p(t)$

$$\int \frac{1}{p - 900} \frac{dp}{dt} dt = \int \frac{1}{2} dt$$

Let's revisit our **population model for mice that we saw in the last example.**

**Example:** The population of Mice,  $p(t)$ , in a field  $t$  months after initial measurements are taken can be modeled by:

$$\frac{dp}{dt} = \frac{p}{2} - 450$$

We found the solution to be given by:  $p = 900 + k \cdot e^{\left(\frac{t}{2}\right)}$

What if we want to use our model to predict the number of mice after 1 year?

In terms of our variables, this is asking: What is  $p(12)$ ?

Because of the unknown constant  $k$ , we are unable to make this prediction.

**Example:** The population of Mice,  $p(t)$ , in a field  $t$  months after initial measurements are taken can be modeled by:

$$\frac{dp}{dt} = \frac{p}{2} - 450$$

## Types of Differential Equations

Similar to Integration in Calculus 2, we will learn techniques to solve Differential Equations

So, recognizing different types of differential equations will be helpful in recognizing which technique to use

All differential equations that we've focused on so far, and all that we will cover in this course are **ordinary differential equations**

An **ordinary differential equation** is a differential equation which uses ordinary derivatives

In contrast, a **partial differential equation** is a differential equation which uses partial derivatives

**Example:** A classical partial differential equation is the Heat Equation:

$$\alpha^2 \frac{\delta^2 u(x, t)}{\delta x^2} = \frac{\delta u(x, t)}{\delta t}$$

where  $\alpha$  is a constant and  $u$  is the heat on a wire at position  $x$  and time  $t$

In future courses, you may study partial differential equations

## Types of Differential Equations

In some applications we will have two unknown functions of the same variable  $t$

A classical example of this in ecology are predator-prey models

Recall(Lecture 1): Field Mice and Owls We may want to revisit our owl and field mice model to factor in what would happen to the owl population, as it would depend on the field mice

When we have differential equations for two different functions that depend on a single variable (and each other) then we call this a system of differential equations

Example:

We will study systems of differential equations later in the course

## Types of Differential Equations

The **order** of a differential equation gives the highest derivative that arises in the differential equation

**Example:** What is the order of the differential equation below?

$$p''' + 2tp'' + e^{5t}p' + p^5 = t^7$$

## Types of Differential Equations

The first type of differential that we will learn to solve is called a **linear** differential equation.

The examples we studied so far are examples of linear diff. eq.

Suppose we have a differential equation of  $y = y(t)$  written as:

$$F(t, y, y', \dots, y^{(n)}) = 0$$

We say that  $y$  is a **linear** differential equation if  $F$  is linear in  $y, y', \dots, y^{(n)}$

Another way of saying this is that we can write the differential equation as:

$$a_0(t)y^{(n)} + a_1(t)y^{(n-1)} + \dots + a_n(t)y = g(t)$$

If a differential is not linear in  $y, y', \dots, y^{(n)}$  then it is called **nonlinear**.



## Types of Differential Equations

A **solution** to a differential equation

$$F(t, y, y', \dots, y^{(n)}) = 0$$

on the interval  $a < t < b$  is a function  $y = s(t)$  that makes the diff. eq. true:

$$F(t, s, s', \dots, s^{(n)}) = 0$$

It is relatively easy to check if a function is a solution to a differential equation.

**Example:** Check that  $y_1 = \cos(t)$  is a solution to:

$$y'' + y = 0$$

## Solving Linear Diff Eq with Integrating Factors

So far, we've used the substitution rule from integration to find solutions to our differential equations. The differential equations we studied there were linear, first-order differential equations with constant coefficients.

We will next look at solving linear, first order differential equations where the coefficients are not necessarily constant. Since a differential equation must only be linear in  $y$  to be a linear differential equation, our generic way of writing a linear, first-order diff. eq. is:

$$\frac{dy}{dt} + p(t) \cdot y = g(t)$$

Recall(Calc 1): The product rule says:

$$\frac{d}{dt}(\mu(t) \cdot y(t)) = \mu(t) \cdot \frac{dy}{dt} + \frac{d\mu}{dt} \cdot y(t)$$

$$\frac{dy}{dt} + p(t) \cdot y = g(t)$$

Recall (Calc 1): The product rule says:

$$\frac{d}{dt} (\mu(t) \cdot y(t)) = \mu(t) \cdot \frac{dy}{dt} + \frac{d\mu}{dt} \cdot y(t)$$

$$\mu(t) \cdot \frac{dy}{dt} + \mu(t) \cdot p(t) \cdot y(t) = \mu(t) \cdot g(t)$$

Notice the similarities between the expressions on the left hand side of this equation and the right hand side of the product rule.

They both start out with  $\mu(t) \cdot \frac{dy}{dt}$

Followed by a function of  $t$  \*times\*  $y$

$$\frac{dy}{dt} + p(t) \cdot y = g(t)$$

We conclude that:

$$\frac{d}{dt} (\mu(t) \cdot y(t)) = \mu(t) \cdot \frac{dy}{dt} + \frac{d\mu}{dt} \cdot y(t) = \mu(t) \cdot \frac{dy}{dt} + \mu(t) \cdot p(t) \cdot y(t) = \mu(t) \cdot g(t)$$

So long as  $\frac{d\mu}{dt} = \mu(t) \cdot p(t)$

$$\frac{dy}{dt} + p(t) \cdot y = g(t)$$

We conclude that:

$$\frac{d}{dt} (\mu(t) \cdot y(t)) = \mu(t) \cdot \frac{dy}{dt} + \frac{d\mu}{dt} \cdot y(t) = \mu(t) \cdot \frac{dy}{dt} + \mu(t) \cdot p(t) \cdot y(t) = \mu(t) \cdot g(t)$$

So long as  $\mu(t) = e^{\int p(t) dt}$

Why is this useful?

If we pick  $\mu(t)$  in such a way, then:

$$\frac{d}{dt} (\mu(t) \cdot y(t)) = \mu(t) \cdot g(t)$$

## Integrating Factors - Example 1

$$\frac{dy}{dt} + p(t) \cdot y = g(t)$$

We can find  $y(t)$  as:

$$y(t) = \frac{1}{\mu} \cdot \int \mu(t) \cdot g(t) dt \quad \text{if } \mu(t) = e^{\left(\int p(t) dt\right)}$$

**Example:** Solve the Differential Equation:

$$\frac{dy}{dt} + \frac{1}{3}y = e^{t/2}$$

## Integrating Factors - Example 2

$$\frac{dy}{dt} + p(t) \cdot y = g(t)$$

We can find  $y(t)$  as:

$$y(t) = \frac{1}{\mu} \cdot \int \mu \cdot g(t) dt \quad \text{if } \mu(t) = e^{\left(\int p(t) dt\right)}$$

Example: Solve the Differential Equation:

$$\frac{dy}{dt} + \frac{2}{t}y = t - 1$$

### Integrating Factors - Example 3

$$\frac{dy}{dt} + p(t) \cdot y = g(t)$$

We can find  $y(t)$  as:

$$y(t) = \frac{1}{\mu} \cdot \int \mu(t) \cdot g(t) dt \quad \text{if } \mu(t) = e^{\left(\int p(t) dt\right)}$$

**Example:** Solve the Differential Equation:

$$t \frac{dy}{dt} = t^2 - t - 2y$$



### Integrating Factors - Application Example

**Example:** Consider a clean pond that holds  $10,000m^3$  of water and has two streams running into it. Water from Stream A flows in at  $500m^3/day$  while Stream B flows in at  $750m^3/day$ . Water flows out Stream C at a rate of  $1250m^3/day$ . At time  $t = 0$  Stream A becomes contaminated with road salt at a concentration of  $5kg/1000m^3$ . Also at this time, someone begins dumping trash into the pond at a rate of  $50m^3/day$ , causing the rate of water flowing out of Stream C to increase to  $1300m^3/day$ .

Let  $S(t)$  be the amount of salt in the pond after  $t$  days of pollution, find  $S(t)$ .

### Integrating Factors - Application Example

This is a linear diff. eq. that can be written in standard form as:

$$\frac{dS}{dt} + \frac{1300}{10000-50t} \cdot S = 2.5$$

## Integrating Factors - Application Example

**Example:** Consider a clean pond that holds  $10,000m^3$  of water and has two streams running into it. Water from Stream A flows in at  $500m^3/day$  while Stream B flows in at  $750m^3/day$ . Water flows out Stream C at a rate of  $1250m^3/day$ . At time  $t = 0$  Stream A becomes contaminated with road salt at a concentration of  $5kg/1000m^3$ . Also at this time, someone begins dumping trash into the pond at a rate of  $50m^3/day$ , causing the rate of water flowing out of Stream C to increase to  $1300m^3/day$ .

**Solution:** 
$$S = \frac{-2.5}{25}(t - 200) + C \cdot (t - 200)^{26} = \frac{-1}{10}(t - 200) + C \cdot (t - 200)^{26}$$

Further, we know that the pond is clean at time  $t = 0$ . That is:  $S(0) = 0$

## Solving Separable Differential Equations

We learned how to solve a special class of first order differential equations - linear ones.

In this section we will study how to solve another class of first-order differential equations - separable first-order differential equations.

A separable first-order differential equation is a differential equation that can be written in the form:

$$N(y)\frac{dy}{dx} = M(x)$$

## Solving Separable Differential Equations

If we have a separable differential equation:

$$N(y) \frac{dy}{dx} = M(x)$$

then we can integrate both sides to get:

$$\int N(y) dy = \int N(y) \frac{dy}{dx} dx = \int M(x) dx$$

**Example:** Find solutions to the Differential Equation:

$$\frac{dy}{dx} = \frac{x^2}{1-y^2}$$

## Solving Separable Differential Equations

The solutions to the differential equation:

$$\frac{dy}{dx} = \frac{x^2}{1-y^2}$$

Satisfy the equation:

$$y - \frac{y^3}{3} = \frac{x^3}{3} + c$$

Note: We cannot solve this equation explicitly for  $y$  by itself

We call this an **implicit solution** to the differential equation

Often times non-linear differential equations, like most separable equations, cannot be solved explicitly.

However, implicit solutions are often just as useful in applications because we can still compute numerical solutions and create integral curves from them.

## Solving Separable Differential Equations - Example 2

**Example:** Find solutions to the Initial Value Problem:

$$\frac{dy}{dx} = \frac{3x^2+4x+2}{2y-2}, \quad y(0) = -1$$

So, we can conclude that  $y$  can be found implicitly as:

$$y^2 - 2y = x^3 + 2x^2 + 2x + 3$$

## Solving Separable Differential Equations - Example 2

The solutions to the differential equation:

$$\frac{dy}{dx} = \frac{3x^2+4x+2}{2y-2}$$

Satisfy the equation:

$$y^2 - 2y = x^3 + 2x^2 + 2x + 3$$

Note: It is preferred to solve a separable diff. eq. explicitly for  $y$  if you can.

Since it is rare that we can find explicit solutions to separable differential equations, we often need to leave our solutions with  $y$  implicitly defined.



### Solving Separable Differential Equations - Example 3

Our method of solving Separable Diff. Eq. relies on computing two integrals.

As we've seen in calculus, some integrals are easier than others to compute.

In this example, we'll need to work a little harder to compute the integral.

**Example:** Find solutions to the Differential Equation:

$$\frac{dv}{dx} = \frac{v^2 + 3v + 2}{x}$$

### Solving Separable Differential Equations - Example 3

The solutions to the differential equation:

$$\frac{dv}{dx} = \frac{v^2+3v+2}{x}$$

Satisfy the implicit equation:

$$\ln \left| \frac{v+1}{v+2} \right| = \ln |x| + c$$

## Homogeneous Differential Equations

In an earlier example, we used a change of variables to change a diff. eq. into a first-order, linear diff. eq.

There is a special class of differential equations, called *homogeneous* differential equations, which can be made into separable differential equation.

A differential equation given by the function:

$$\frac{dy}{dx} = f(x, y)$$

where  $f(x, y)$  can be written in terms of  $\frac{y}{x}$ , is called *homogeneous*.

A homogeneous diff. eq. can be changed into a separable diff. eq. with the change of variables:  $v = \frac{y}{x}$

**Example:** The following differential equation is homogeneous

$$\frac{dy}{dx} = \frac{2x^2 + 4xy + y^2}{x^2}$$

## Homogeneous Differential Equations

**Example:** Solve the homogeneous differential equation

$$\frac{dy}{dx} = \frac{2x^2 + 4xy + y^2}{x^2} = 2 + 4\frac{y}{x} + \left(\frac{y}{x}\right)^2$$

As noted, we can solve this using a change of variables:  $v = \frac{y}{x}$

With this change of variables, we can write the right hand side as:  $2 + 4v + v^2$

We, also, need to change the left hand side,  $\frac{dy}{dx}$ , to be in terms of  $v$

### Mathematical Modeling Revisited - Bank example

**Example:** The rate at which interest earned on invested money is proportional to the amount of money in the account. This proportionality constant is called the annual interest rate,  $r$ . Find the amount of money,  $S(t)$ , in an account  $t$  years after a deposit of  $S_0$  is made.

Note: Here, we are assuming that interest is compounded continuously. In practice interest is most typically compounded daily, monthly, or yearly.

## Mathematical Modeling Revisited - Bank example

**Example:** The amount of money,  $S(t)$ , in an account earning an interest rate,  $r$ , after  $t$  years is:

$$S(t) = S_0 e^{(rt)}$$

If you earn an interest rate of 6% on money invested at age 22, by what multiple will your investment grow by the time you reach age 65?

## Mathematical Modeling Revisited - Bank example

**Example:** Let the amount of money  $t$  years after making an initial deposit of  $S_0$ , be written as  $S(t)$ . If the money is in an account earning an interest rate,  $r$ , then  $S(t)$  can be model by the IVP:

$$\frac{dS}{dt} = rS \quad S(0) = S_0$$

Suppose further that you make regular deposits, totaling  $\$D$  per year.

How will this impact our model?

## Mathematical Modeling Revisited - Bank example

**Example:** Suppose that you open retirement account with 6% interest rate at age 22. You initially invest \$1000 and deposit \$6000 per year until you retire at age 65. How much money will you have in the account when you retire?

So  $c = \frac{101000}{6000} = \frac{101}{6}$  and we find:



Mathematical models are used in many disciplines outside of math to study various applications, such as the population and physical examples we've looked at.

It is often helpful to leave some constants as parameters, that can vary within the application, to best study these ideas.

By allowing certain parameters to vary, we can study their impact on an application.

As examples, we will build models using these parameters to see how they can help us analyze an application.

In practice, it is good to run experiments to test if the theoretical results found in analyzing the model accurately describe the results found in the experiment.

Though, sometimes this can be too costly, or not possible, and we need to rely on the model.

## Mathematical Modeling Revisited

**Example:** A tank at  $t = 0$  has  $Q_0$  lb of salt dissolved in 100 gal of water. Assume that water containing  $1/4$  lb of salt per gallon is entering the tank at a rate of  $r$  gallons per minute and the water is leaving the tank at the same rate. Find the limiting amount,  $Q_L$ , of the amount of salt in the tank in the long run.

## Mathematical Modeling Revisited

**Example:** A tank at  $t = 0$  has  $Q_o$  lb of salt dissolved in 100 gal of water. Assume that water containing  $1/4$  lb of salt per gallon is entering the tank at a rate of  $r$  gallons per minute and the water is leaving the tank at the same rate. We found the limiting amount of salt in the tank,  $Q_L$ , to be  $Q_L = 25$ .

If the amount of salt starts at twice the limiting amount,  $Q_o = 2Q_L = 50$ , find  $r$  so that it takes 45 minutes for  $Q(t)$  to be within 2% of  $Q_L$ .

Note: This analysis would be difficult to do without our model, as we would need to run multiple experiments varying  $r$ .

## Autonomous Differential Equations

**Definition:** A **Autonomous Differential Equation** is diff. eq. of the form:

$$\frac{dy}{dt} = f(y)$$

That is, a differential equation where  $\frac{dy}{dt}$  can be written in terms of just  $y$ .

We have seen examples in Compound Interest and Modeling mouse populations

Our most basic population model says that the rate of change of a population is proportional to the population. That is:

$$\frac{dy}{dt} = ry$$

where  $y$  is the population and  $r$  is the growth rate.

This is an example of an autonomous differential equation.

For a starting population  $y(0) = y_0$ , we can obtain the solution:

$$y = y_0 e^{rt}$$

## Autonomous Differential Equations

First model: For the population model  $\frac{dy}{dt} = ry$  and initial population  $y(0) = y_0$  we have the solution:

$$y = y_0 e^{rt}$$

The problem with this model is that the long run behavior of  $y$  is to tend towards  $\infty$ , which does not make sense in a real world application.

Natural environments can only sustain so large of a population. We call this maximum population that an environment can sustain the **carrying capacity**.

## Autonomous Differential Equations

**Logistic growth model:** A population with growth rate,  $r$ , and carrying capacity,  $K$ , can be modeled by:

$$\frac{dy}{dt} = r \left( 1 - \frac{y}{K} \right) y$$

Let's analyze this model by looking at its equilibrium solutions.

The eq. sol. happen when  $\frac{dy}{dt} = 0$ , which for this diff. eq. is:

$$r \left( 1 - \frac{y}{K} \right) y = 0$$

## Autonomous Differential Equations

**Logistic growth model:** A population with growth rate,  $r$ , and carrying capacity,  $K$ , can be modeled by:  $\frac{dy}{dt} = r \left(1 - \frac{y}{K}\right) y$

Equilibrium solutions occur at  $y = 0$  and  $y = K$

What can we conclude about other solutions?

So, we can conclude that if  $y > K$  then  $y$  is decreasing.

We can do a similar analysis for  $0 < y < K$  and  $y < 0$

So, we can conclude that if  $0 < y < K$  then  $y$  is increasing.

So, we can conclude that if  $y < 0$  then  $y$  is decreasing.

Autonomous Differential Equations

Logistic growth model: A population with growth rate,  $r$ , and carrying capacity,  $K$ , can be modeled by:  $\frac{dy}{dt} = r(1 - \frac{y}{K})y$

Equilibrium solutions occur at  $y = 0$  and  $y = K$

If we look at the integral curves with the phase, we can draw further conclusions about our equilibrium solutions.

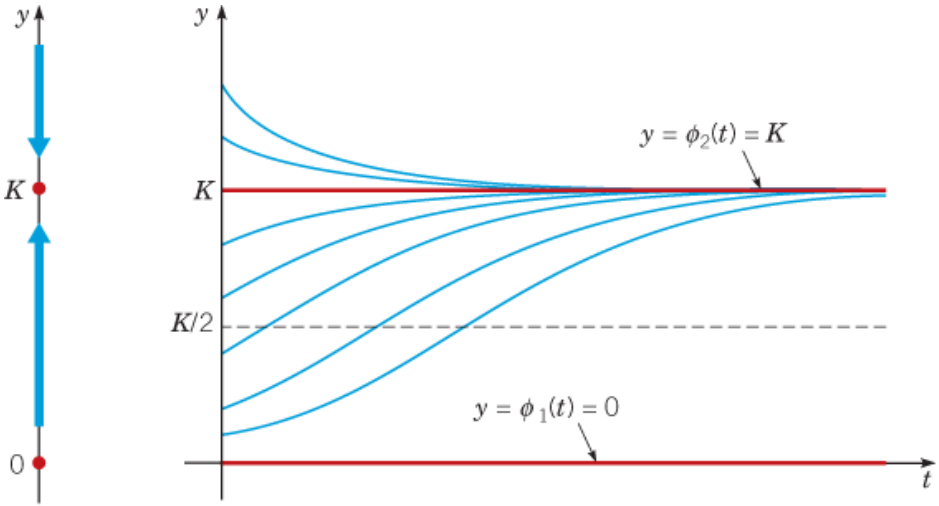



## Autonomous Differential Equations - Example 2

**Example:** Find and classify the equilibrium solutions of the autonomous differential equation:

$$\frac{dy}{dt} = y(y + 3)(y - 2)$$

### Autonomous Differential Equations - Example 3

**Example:** Find and classify the equilibrium solutions of the autonomous differential equation:

$$\frac{dy}{dt} = y^2(y + 3)(y - 2)$$

## Existence and Uniqueness of Differential Equations

We have spent most of our work, thus far, studying and finding solutions to differential equations.

Will we always be able to find a solution?

What if we're looking for a solution that doesn't exist?

What if we find a solution? Are there other solutions we're missing?

**Theorem:** Existence and Uniqueness Theorem for First-Order Linear Equations

If the functions  $p(t)$  and  $g(t)$  are continuous on the open interval  $\alpha < t < \beta$  containing  $t = t_0$ , then there exists a unique function  $y = y_1(t)$  that satisfies the differential equation

$$y' + p(t)y = g(t)$$

for all  $\alpha < t < \beta$  that satisfies an initial condition  $y(t_0) = y_0$ .

The proof of this relies on the existence of the integrating factor  $\mu(t) = e^{\int p(t)dt}$

## Existence and Uniqueness of Differential Equations

**Theorem:** Existence and Uniqueness Theorem for First-Order Linear Equations

If the functions  $p(t)$  and  $g(t)$  are continuous on the open interval  $\alpha < t < \beta$  containing  $t = t_0$ , then there exists a unique function  $y = y_1(t)$  that satisfies the differential equation

$$y' + p(t)y = g(t)$$

for all  $\alpha < t < \beta$  that satisfies an initial condition  $y(t_0) = y_0$ .

What about Differential Equations that are non-Linear?

**Theorem:** Existence and Uniqueness for First-Order Differential Equations

Let the functions  $f(t, y)$  and  $\frac{\partial f}{\partial y}$  be continuous in some rectangle  $\alpha < t < \beta$  and  $\gamma < y < \delta$  containing the point  $(t_0, y_0)$ .

Then in some subinterval  $t_0 - h < t < t_0 + h$  contained in  $\alpha < t < \beta$ , there is a unique solution  $y = y_1(t)$  of the initial value problem

$$y'(t) = f(t, y), \quad y(t_0) = y_0$$

The proof of this theorem is left to future courses.

**Important Note:** The uniqueness of solutions guarantees that the graphs of two solutions of a differential equation cannot intersect.

## Existence and Uniqueness of Differential Equations

**Example:** Find the solution to

$$y' = y^2, \quad y(0) = 1$$

and find the interval where the solution exists.

Our theorems tell us that unique solutions to these differential equations exist.

But they do not guarantee that we can find them!

And sometimes we cannot find solutions because the solutions cannot be written in closed form - that is solutions that can be written in terms of our usual functions.

So, what do we do if we know a function exists but we can't find it?

Numerical methods exist to find approximations to the solutions.

In practice, these approximations are as useful as the actual solution.

We will study one such method called Euler's Method soon!

## Existence and Uniqueness Theorem - Non-Example

The Existence and Uniqueness theorem gives conditions on a differential equation that guarantee solutions exist and are unique.

What if these conditions aren't met?

Consider the Initial Value Problem:

$$\frac{dy}{dx} = \frac{x}{y} \text{ with } y(1) = 0$$

## Existence and Uniqueness Theorem - Non-Example

Consider the Initial Value Problem:

$$\frac{dy}{dx} = \frac{x}{y} \text{ with } y(1) = 0$$

We can see this is separable by multiplying by  $y$  to get:  $y \cdot \frac{dy}{dx} = x$



## Euler's Method

We have learned how to solve several different types of differential equations.

However, there are many more differential equations out there that do not fit into one of the types we know how to solve.

While the existence and uniqueness theorems tell us that solutions exist, how do we understand the solutions to these differential equations that we do not have techniques to solve directly?

There are methods to find numerical approximation of the solutions to differential equations.

One such method, that we will look at, is called Euler's Method.

## Euler's Method

Suppose that we want to find a numerical approximation of the differential equation given by:

$$\frac{dy}{dt} = f(t, y) \quad \text{with initial condition: } y(t_0) = y_0$$

## Euler's Method

Suppose that we want to find a numerical approximation of the differential equation given by:

$$\frac{dy}{dt} = f(t, y) \quad \text{with initial condition: } y(t_0) = y_0$$

The linear approximation to the solution,  $y(t)$ , near  $(t_0, y_0)$  is:

$$y(t) \approx y_0 + f(t_0, y_0) \cdot (t - t_0)$$

Suppose we want an approximation for  $y(b)$  for some value  $t = b$ .

## Euler's Method

To find a numerical approximation to the Initial Value Problem:

$$\frac{dy}{dt} = f(t, y) \quad \text{with initial condition: } y(t_0) = y_0$$

We can iteratively find a sequence of approximations with step size  $h$ :

$$t_{i+1} = t_i + h = t_0 + i \cdot h$$

$$y_{i+1} = y_i + f(t_i, y_i) \cdot h$$

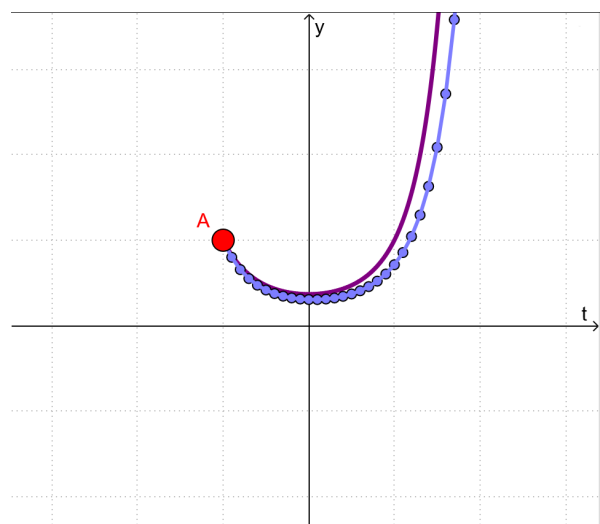
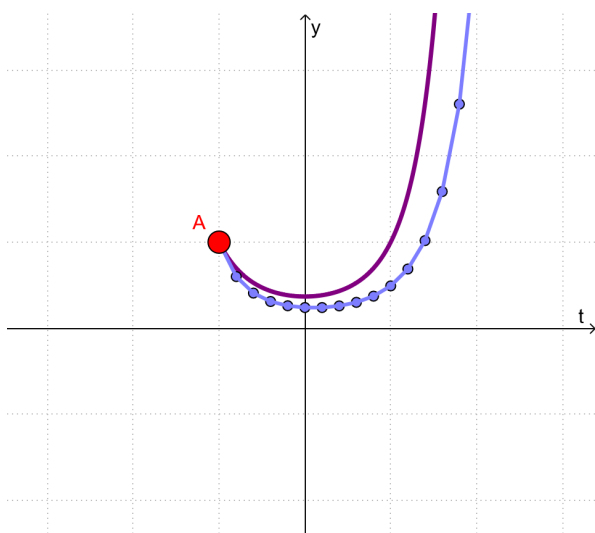

## Euler's Method

**Example:** Use Euler's Method with step size  $h = 0.1$  to find approximations for  $t = 0.1, 0.2, \dots, 0.9, 1$  of the solution to the initial value problem:

$$\frac{dy}{dt} = (y - 1) \cdot (y - 3) \quad \text{with } y(0) = 2$$

## Exact Equations

So far, we have learned two major methods for solving differential equations.

Linear differential equations and Separable differential equations

Most differential equations, however, do not fit into either of these categories

We will learn one more method for solving a specific type of first order differential equations

For others, we will need to find numerical approximations for the solutions.

Let's start by looking at an example that we cannot solve using our current methods.

## Exact Equations

**Example:** Solve the differential equation:  $3x^2 + y^2 + 2xy \frac{dy}{dx} = 0$

While it is very difficult to spot, we can verify that  $\psi(x, y) = x^3 + xy^2$  has the property that the partial derivatives play a defining role in our diff. eq.

In particular,  $\psi_x = 3x^2 + y^2$  and  $\psi_y = 2xy$  with our differential equation:

$$3x^2 + y^2 + 2xy \frac{dy}{dx} = 0$$

## Exact Equations

We were able to find the implicit solution:

$$x^3 + xy^2 = c$$

to the differential equation:  $3x^2 + y^2 + 2xy \frac{dy}{dx} = 0$

because we were given  $\psi = x^3 + xy^2$  such that  $\psi_x = 3x^2 + y^2$  and  $\psi_y = 2xy$

This process can be repeated, so long as we can find such a  $\psi(x, y)$

In General: A differential equation of the form:

$$M(x, y) + N(x, y) \cdot \frac{dy}{dx} = 0$$

such that  $M(x, y) = \psi_x(x, y)$  and  $N(x, y) = \psi_y(x, y)$  for some function  $\psi(x, y)$  is called an **exact differential equation**. The implicit solution is  $\psi(x, y) = c$



## Exact Equations

In General: A differential equation of the form:

$$M(x, y) + N(x, y) \cdot \frac{dy}{dx} = 0$$

such that  $M(x, y) = \psi_x(x, y)$  and  $N(x, y) = \psi_y(x, y)$  for some function  $\psi(x, y)$  is called an **exact differential equation**. The implicit solution is  $\psi(x, y) = c$

## Exact Equations

For the differential equation  $M(x, y) + N(x, y) \cdot \frac{dy}{dx} = 0$ , suppose that  $M_y = N_x$

We will construct a function  $\psi(x, y)$  such that  $\psi_x = M$  and  $\psi_y = N$  to show that this diff. eq. is exact

## Exact Equations - Example

**Example:** Solve the differential equation:

$$y \cdot \sin(x) + e^y + (xe^y - \cos(x) + 1)y' = 0$$

## Second Order Differential Equations

Thus far, we have studied First-Order Diff. Eq., which have the form:

$$\frac{dy}{dt} = f(t, y)$$

We will now begin our study of Second-Order Differential Equations, which have the form:

$$\frac{d^2y}{dt^2} = f\left(t, y, \frac{dy}{dt}\right)$$

We will restrict our discussion to **linear** second-order differential equations, which can be written as:

$$P(t)y'' + Q(t)y' + R(t)y = G(t)$$

We will begin our conversation by looking at differential equations where  $G(t) = 0$ , which are called **homogeneous** and, furthermore, where the coefficients are constant.

Such Second-Order Homogeneous Differential Equations with Constant Coefficients look like:

$$ay'' + by' + cy = 0$$

We will study Second-Order Nonhomogeneous Differential Equations with Constant Coefficients in coming lectures.

## Second Order Differential Equations - Example

**Example:** Find solutions of the differential equation:

$$y'' - y = 0$$

Can we guess solutions to this differential equation based on our knowledge of derivatives?

## Second Order Differential Equations - Example

We will use this example to lead us to solutions of diff. eq. of the form:

$$ay'' + by' + cy = 0$$

We will look for solutions of the form  $y = e^{rt}$  for some value of  $r$

## Second Order Differential Equations - Example 2

**Example:** Find solutions to the differential equation:

$$y'' + 15y' - 34y = 0$$

## Second Order Differential Equations - Example with IVP

**Example:** Find a solution to the Initial Value Problem:

$$y'' + y' - 12y = 0 \text{ with } y(0) = 2, y'(0) = 1$$



## Second Order Differential Equations - Example with IVP

**Example:** Find solutions to the Initial Value Problem:

$$y'' + y' - 12y = 0 \text{ with } y(0) = 2, y'(0) = 1$$

**Solution:** We can, further, conclude that for constants  $c_1, c_2$  all functions of the form:

$$y = c_1 e^{-4t} + c_2 e^{3t}$$

are solutions to the differential equation.

### Existence and Uniqueness Theorem for 2nd-order Diff. Eq.

For linear, first-order differential equations, we saw that if the functions  $p(t)$  and  $g(t)$  are continuous on the open interval  $\alpha < t < \beta$  containing  $t = t_0$ , then there exists a unique function  $y = y_1(t)$  that satisfies the differential equation

$$y' + p(t)y = g(t)$$

for all  $\alpha < t < \beta$  that satisfies an initial condition  $y(t_0) = y_0$ .

### Theorem: Existence and Uniqueness Theorem for Second-Order Linear Diff Eq

If the functions  $p(t)$ ,  $q(t)$ , and  $g(t)$  are continuous on the open interval  $\alpha < t < \beta$  containing  $t = t_0$ , then there exists a unique function  $y = y_1(t)$  that satisfies the differential equation

$$y'' + p(t)y' + q(t)y = g(t)$$

for all  $\alpha < t < \beta$  and satisfies initial conditions  $y(t_0) = y_0$  and  $y'(t_0) = y'_0$ .

### Existence and Uniqueness Theorem - Example

**Example:** Find the longest interval on which the **Existence and Uniqueness Theorem** guarantees a unique, twice differentiable solution to:

$$t(t + 4)y'' + y' + ty = 3 \text{ with } y(1) = 4 \text{ and } y'(1) = -1$$

We saw that the differential equation:

$$ay'' + by' + cy = 0$$

has an associated characteristic equation  $a^2r + br + c = 0$  such that the solutions of the differential equation are  $y_1 = e^{r_1 t}$  and  $y_2 = e^{r_2 t}$  where the constants  $r_1, r_2$  are solutions to the characteristic equation.

Moreover, we will show that if  $y_1$  and  $y_2$  are solutions to  $ay'' + by' + cy = 0$  then there is an infinite family of solutions of the form:

$$y = c_1 y_1(t) + c_2 y_2(t)$$

But are there more solutions to the differential equation that we're missing?

Or, conversely, is the above family of solutions the general solution?

We will show that this is, in fact, the general solution.

The statement of our theorem will be for a more general class of differential equations:

$$y'' + p(t)y' + q(t)y = 0$$

## Wronskian - Families of Solutions

We will start by showing that if  $y_1$  and  $y_2$  are solutions to  $y'' + p(t)y' + q(t)y = 0$  then  $y = c_1y_1(t) + c_2y_2(t)$  is a solution, as well, for any constant values of  $c_1, c_2$

Proof: Suppose that  $y_1$  and  $y_2$  are solutions to  $\mathbf{y}'' + \mathbf{p}(t)\mathbf{y}' + \mathbf{q}(t)\mathbf{y} = \mathbf{0}$

## Wronskian - General Solutions

**Theorem:** Suppose that  $y_1$  and  $y_2$  are solutions to the differential equation:

$$y'' + p(t)y' + q(t)y = 0$$

Let  $y(t)$  be a solution which has the initial conditions:  $y(t_0) = y_0$ ,  $y'(t_0) = y'_0$

Then there are always constants  $c_1, c_2$  so that:

$$y = c_1 \cdot y_1(t) + c_2 \cdot y_2(t)$$

satisfies the initial value problem if and only if:

$$y_1 y_2' - y_1' y_2 \neq 0 \quad \text{at } t = t_0$$

## Wronskian - General Solutions of Exponentials

**Example:** Suppose that  $y_1 = e^{r_1 t}$  and  $y_2 = e^{r_2 t}$  are solutions to a differential equation of the form  $y'' + p(t)y' + q(t)y = 0$ . Check if  $y = c_1 e^{r_1 t} + c_2 e^{r_2 t}$  is the general solution.

## Wronskian - General Solutions of Exponentials Example

**Example:** Find the general solution of:

$$y'' + y' - 12y = 0$$



## Abel's Theorem

We have shown that if the  $y_1$  and  $y_2$  are solutions to the differential equation:

$$y'' + p(t)y' + q(t)y = 0$$

and  $W[y_1, y_2](t_0) \neq 0$ , then the general solution of the differential equation is:

$$y = c_1 \cdot y_1(t) + c_2 \cdot y_2(t)$$

This relies on evaluating  $W[y_1, y_2]$  at a value  $t = t_0$ .

A question to consider is: Does it matter which value  $t = t_0$  we choose?

### Theorem: Abel's Theorem

If  $y_1$  and  $y_2$  are solutions to the diff. eq.:

$$y'' + p(t)y' + q(t)y = 0$$

with  $p(t)$  and  $q(t)$  continuous on an open interval  $(\alpha, \beta)$ , then:

$$W[y_1, y_2](t) = c \cdot e^{\left(-\int p(t)dt\right)}$$

where  $c$  is a constant depending on  $y_1, y_2$  but independent of  $t$ .

## Abel's Theorem

**Theorem:** Abel's Theorem

If  $y_1$  and  $y_2$  are solutions to the diff. eq.:

$$y'' + p(t)y' + q(t)y = 0$$

with  $p(t)$  and  $q(t)$  continuous on an open interval  $(\alpha, \beta)$ , then:

$$W[y_1, y_2](t) = c \cdot e^{-\int p(t)dt}$$

where  $c$  is a constant depending on  $y_1, y_2$  but independent of  $t$ .

We saw that the differential equation:

$$ay'' + by' + cy = 0$$

has an associated characteristic equation  $ar^2 + br + c = 0$  such that the solutions of the differential equation are  $y_1 = e^{r_1 t}$  and  $y_2 = e^{r_2 t}$  where the constants  $r_1, r_2$  are solutions to the characteristic equation.

Further, we saw that if  $r_1 \neq r_2$ , we could build the general solution:

$$y = c_1 e^{r_1 t} + c_2 e^{r_2 t}$$

However, since the characteristic equation is a quadratic polynomial, there are three possibilities for the roots.

The case above is when the char. poly. has 2 distinct, real roots.

Another possibility is that the char. poly. has 2 complex roots

And the final possibility is that the char. poly. has 1 repeated, real root.

We will study these last two possibilities, starting with the complex case.

**Theorem:** If  $y = u(t) + iv(t)$  is a complex-valued solution of a differential equation of the form:

$$y'' + p(t)y' + q(t)y = 0$$

then  $u(t)$  and  $v(t)$  are both real-valued solutions to this differential equation.

**Theorem:** If  $y = u(t) + iv(t)$  is a complex-valued solution of a differential equation of the form:

$$y'' + p(t)y' + q(t)y = 0$$

then  $u(t)$  and  $v(t)$  are both real-valued solutions to this differential equation.

We have shown that, since  $u(t)$ ,  $v(t)$  are solutions:

$$y = c_1 u(t) + c_2 v(t)$$

is an infinite family of solutions.

Is it the general solution?

Suppose that the differential equation  $ay'' + by' + cy = 0$  has a characteristic equation that yields complex roots,  $r_1, r_2$ .

That is, the solutions to  $ar^2 + br + c = 0$  are complex.

How do we split  $y = e^{(\gamma+i\mu)t}$  into its **real** and **imaginary** parts?

We just saw that if  $r = \gamma + i \cdot \mu$  is a complex solution to its char. eq. then

$$y_1 = e^{\gamma t} \cdot \cos(\mu t) \text{ and } y_2 = e^{\gamma t} \cdot \sin(\mu t)$$

are real solutions to the differential equation:

$$ay'' + by' + cy = 0$$

We have also seen that if  $y_1$  and  $y_2$  are solutions to  $y'' + p(t)y' + q(t)y = 0$  then  $y = c_1 y_1(t) + c_2 y_2(t)$  is a solution, as well, for any constant values of  $c_1, c_2$

Combining these ideas, we see that, for any constants  $c_1, c_2$ :

$$y = c_1 e^{\gamma t} \cdot \cos(\mu t) + c_2 e^{\gamma t} \cdot \sin(\mu t) \text{ is a solution.}$$

To conclude that this is the General Solution, we need the Wronskian,  $W \neq 0$

Computing the  $W$ , we can show that  $W = \mu e^{(2\gamma t)}$  and, thus:

$$W = 0 \text{ if and only if } \mu = 0$$

But, in the case that  $\mu = 0$ , the roots to the char. eq. are not complex.

**Conclusion:** If  $r = \gamma + i \cdot \mu$  is a complex solution to its char. eq. then

$$y = c_1 e^{\gamma t} \cdot \cos(\mu t) + c_2 e^{\gamma t} \cdot \sin(\mu t)$$

is the General Solution to the differential equation:  $ay'' + by' + cy = 0$



Homogeneous Diff. Eq. w/ Const. Coeff - Complex Case

**Example:** Find the General Solution of:

$$y'' + 2y' + 5y = 0$$

**Example:** Find the Solution of the IVP:

$$y'' - 4y' + 13y = 0 \quad \text{with } y(0) = 1 \text{ and } y'(0) = 8$$

## Homogeneous Diff. Eq. w/ Const. Coeff - Repeated Roots

We saw that if the number  $r$  is a solution to the char. eq.:  $ar^2 + br + c = 0$  then the function  $y = e^{rt}$  is a solution to the diff. eq.:  $ay'' + by' + cy = 0$

We, also, saw that if  $y_1(t)$  and  $y_2(t)$  are solutions to the diff. eq.:  $ay'' + by' + cy = 0$  and the Wronskian  $W[y_1, y_2] \neq 0$  then the general solution to the diff. eq. is:

$$y(t) = c_1 y_1(t) + c_2 y_2(t)$$

Whether  $r$  was real or complex, we could always find two functions  $y_1, y_2$  to form the general solution.

There is one more case that can come up.

What if characteristic equation only has one, repeated, real root?

That is, what if  $ar^2 + br + c = a(r - \gamma)^2$  for some  $\gamma \in \mathbf{R}$  ?

We know that  $y_1 = e^{\gamma t}$  is a solution. But can we find a second solution  $y_2$  to build the general solution?

We saw for complex roots that the solutions looked like  $e^{\gamma t} \cos(\mu t)$ ,  $e^{\gamma t} \sin(\mu t)$

This guides us to check for the second solution as a function of the form  $v(t)e^{\gamma t}$  for some function  $v(t)$ .

### Homogeneous Diff. Eq. w/ Const. Coeff - Repeated Roots

We saw that if  $y_1(t)$  and  $y_2(t)$  are solutions to the diff. eq.:  $ay'' + by' + cy = 0$  and the Wronskian  $W[y_1, y_2] \neq 0$  then the general solution to the diff. eq. is:

$$y(t) = c_1y_1(t) + c_2y_2(t)$$

If the characteristic equation  $ar^2 + br + c = a(r - \gamma)^2$  for some  $\gamma \in \mathbf{R}$ , we know that  $y_1 = e^{\gamma t}$  is a solution.

Our work with complex guides us to think that the second solution may be of the form:

$$y_2 = v(t)e^{\gamma t}$$

We can show that for  $y_2 = v(t)e^{\gamma t}$  to be a solution, then  $v(t) = t$

Suppose that the differential equation  $ay'' + by' + cy = 0$ , with characteristic equation  $ar^2 + br + c = 0$  has a repeated real root,  $\gamma$ .

We want to find a function  $v(t)$  so that  $y = v(t)e^{\gamma t}$  is a solution.

For the solutions  $y_1 = e^{\gamma t}$  and  $y_2 = te^{\gamma t}$ , we wish to show that  $W[y_1, y_2] \neq 0$

To do this, we wish to compute the derivatives  $y_1'$  and  $y_2'$

Hom. Diff. Eq. w/ Const. Coeff - Repeated Roots Example

**Example:** Find the solution to the Initial Value Problem:

$$y'' + 8y' + 16y = 0 \text{ with } y(0) = 5 \text{ and } y'(0) = -3$$

We have now seen how to solve differential equations of the form:

$$ay'' + by' + cy = 0$$

We will now study the non-homogeneous case:

$$ay'' + by' + cy = g(t)$$

As we did with the homogeneous case, we will build much of our theory for more general linear differential equations:

$$y'' + p(t)y' + q(t)y = g(t)$$

We will start by showing that:

**Theorem:** If  $Y_1$  and  $Y_2$  are two solutions to the nonhomogeneous diff. eq.:

$$y'' + p(t)y' + q(t)y = g(t)$$

then  $Y_1 - Y_2$  is a solution to the associated homogeneous diff. eq.:

$$y'' + p(t)y' + q(t)y = 0$$



## Nonhomogeneous Diff. Eq. w/ Const. Coeff

**Theorem:** If  $Y_1$  and  $Y_2$  are two solutions to the nonhomogeneous diff. eq.:

$$y'' + p(t)y' + q(t)y = g(t)$$

then  $Y_1 - Y_2$  is a solution to the associated homogeneous diff. eq.:

$$y'' + p(t)y' + q(t)y = 0$$

This theorem allows us to build a general solution to the non-homog. diff. eq.

**Theorem:** If  $y_p$  is a particular solution of the non-homogeneous diff. eq.

$$y'' + p(t)y' + q(t)y = g(t)$$

then the general solution can be written in terms of  $y_1, y_2$ , solutions to the associated homog. diff. eq. (with  $W[y_1, y_2] \neq 0$ ) and constants  $c_1, c_2$  as:

$$y(t) = y_p(t) + c_1y_1 + c_2y_2$$

## Nonhomogeneous DE w/ Const. Coeff - Particular Solutions

**Theorem:** If  $y_p$  is a particular solution of the non-homogeneous diff. eq.

$$y'' + p(t)y' + q(t)y = g(t)$$

then the general solution can be written in terms of  $y_1, y_2$ , solutions to the associated homog. diff. eq. (with  $W[y_1, y_2] \neq 0$ ) and constants  $c_1, c_2$  as:

$$y(t) = y_p(t) + c_1y_1 + c_2y_2$$

Since we learned how to find the general solution to any homogeneous second-order differential equation with constant coefficients, we can solve any nonhomogeneous second-order differential equation with constant coefficients of the form:

$$ay'' + by' + cy = g(t)$$

so long as we can find one particular solution  $y_p(t)$ .

We now need a technique to find one particular solution  $y_p(t)$  to the non-homogeneous differential equation.

The particular solution,  $y_p(t)$ , will depend on  $g(t)$

Thus, our approach will use  $g(t)$  to determine the form of  $y_p(t)$ .

We will look at several examples where we find  $y_p(t)$ .

Example: Find a particular solution to:

$$y'' - y' - 6y = e^{2t}$$

We need to try to find a function  $y(t)$  that is a solution to this diff. eq.

That is, we need a function  $y(t)$  that balances both sides of the equation

Since  $e^{2t}$  appears on the right hand side, we will need  $e^{2t}$  to be on the left hand side in order for both sides to be equal.

The easiest way to achieve this is try the form  $y(t) = Ae^{2t}$  for some  $A$

To see if  $y(t)$  is a solution, for some  $A$ , we check  $y(t)$  in the diff. eq.

To do this, we need to compute:  $y'(t) = 2Ae^{2t}$  and  $y''(t) = 4Ae^{2t}$

Checking this in the differential equation, we get:

$$4Ae^{2t} - 2Ae^{2t} - 6Ae^{2t} = e^{2t}$$

Simplifying the left hand side yields the equation:  $-4Ae^{2t} = e^{2t}$

Thus, we can conclude that for  $A = -\frac{1}{4}$ ,  $y(t) = Ae^{2t}$  is a solution.

That is,  $y(t) = -\frac{1}{4}e^{2t}$  is a particular solution to the diff. eq.

Example: Find the general solution to:

$$y'' - y' - 6y = e^{2t}$$

We saw that if  $y_p$  is a particular solution of the non-homogeneous diff. eq.

$$y'' + p(t)y' + q(t)y = g(t)$$

then the general solution can be written in terms of  $y_1, y_2$ , solutions to the associated homog. diff. eq. (with  $W[y_1, y_2] \neq 0$ ) and constants  $c_1, c_2$  as:

$$y(t) = y_p(t) + c_1y_1 + c_2y_2$$

And we just found a particular solution:  $y(t) = -\frac{1}{4}e^{2t}$

Thus, we can find the general solution by finding the solution to the associated homogeneous diff. eq.:

$$y'' - y' - 6y = 0$$

We can find the gen. sol. to the homog. diff. eq. by looking at its char. eq.

$$r^2 - r - 6 = 0$$

Solving this, we get  $r_{1,2} = -2, 3$

Thus, the general solution of the homog. diff. eq. is:  $y_h = c_1e^{-2t} + c_2e^{3t}$

With a particular solution of the non-homog. diff. eq. and the gen. sol. of the assoc. homog. diff. eq. we can build the gen. sol. of the non-homog. diff. eq.:

$$y(t) = -\frac{1}{4}e^{2t} + c_1e^{-2t} + c_2e^{3t}$$

## Nonhomogeneous Diff. Eq. w/ Const. Coeff IVP

**Example:** Solve the Initial Value Problem:

$$y'' + 3y' - 18y = e^{-2t} \quad y(0) = 3 \text{ and } y'(0) = 5$$

**Solution:** We start by finding the **gen. sol. to the associated homogeneous DE:**

$$y'' + 3y' - 18y = 0$$

By factoring the char. eq.:  $0 = r^2 + 3r - 18 = (r - 6) \cdot (r + 3)$

We get roots  $r_1 = 6$  and  $r_2 = -3$  which gives the **gen. sol. to the homog. DE:**

$$y_h = c_1 e^{6t} + c_2 e^{-3t} \quad c_1, c_2 - \text{constant}$$

Next, we need to find a **particular solution to the non-homogeneous DE**

Based on the RHS  $e^{-2t}$ , our **particular solution** will have the form:  $y_p = Ae^{-2t}$

Using  $y_p' = -2Ae^{-2t}$  and  $y_p'' = 4Ae^{-2t}$  in our DE, we can solve for  $A$ :

Thus  $y_p = \frac{-1}{20}e^{-2t}$ , and the gen. sol. of the Non-homog. DE is:

$$y(t) = \frac{-1}{20}e^{-2t} + c_1 e^{6t} + c_2 e^{-3t}$$

Now that we have the **general solution of the non-homog. DE**, we can impose the initial conditions **to solve for  $c_1$  and  $c_2$**

Doing so, we find that  $c_1 = \frac{67}{45}$  and  $c_2 = \frac{281}{180}$

Putting this together, we get that the solution to the initial value problem is:

$$y(t) = \frac{-1}{20}e^{-2t} + \frac{67}{45}e^{6t} + \frac{281}{180}e^{-3t}$$

### Nonhomogeneous Diff. Eq. Initial Conditions

We found the general solution of the differential equation in the IVP:

$$y'' + 3y' - 18y = e^{-2t} \quad y(0) = 3 \text{ and } y'(0) = 5$$

to be:

$$y(t) = \frac{-1}{20}e^{-2t} + c_1e^{6t} + c_2e^{-3t}$$

Now that we have the **general solution of the non-homog. DE**, we can impose the initial conditions to solve for  $c_1$  and  $c_2$

## Nonhomogeneous DE w/ Const. Coeff - Example 1

**Example:** Find the general solution to:

$$y'' - y' - 6y = \sin(2t)$$

## Nonhomogeneous DE w/ Const. Coeff - Polynomial Ex

**Example:** Find the general solution to:

$$y'' - y' - 6y = 3t$$



## Nonhomogeneous DE w/ Const. Coeff - Example 2

**Example:** Find the general solution to:

$$y'' - y' - 6y = e^{3t}$$

### Nonhomogeneous DE w/ Const. Coeff - Example 3

**Example:** Find the general solution to:

$$y'' - 4y' + 4y = e^{2t}$$

#### Nonhomogeneous DE w/ Const. Coeff - Example 4

In each of our examples thus far, solving nonhomog. diff. eq.:

$$y''(t) + p(t)y'(t) + q(t)y(t) = g(t)$$

we have had only one term for  $g(t)$

What if  $g(t)$  has multiple terms, with the form:

$$y''(t) + p(t)y'(t) + q(t)y(t) = g_1(t) + g_2(t)$$

This does not impact the general solution to the assoc. homog. diff. eq.

But how can we find a particular solution?

**Theorem:** If  $y_p$  and  $y_q$  are solutions to:

$$y''(t) + p(t)y'(t) + q(t)y(t) = g_1(t) \text{ and } y''(t) + p(t)y'(t) + q(t)y(t) = g_2(t)$$

respectively, then  $y_p + y_q$  is a solution of:

$$y''(t) + p(t)y'(t) + q(t)y(t) = g_1(t) + g_2(t)$$

#### Nonhomogeneous DE w/ Const. Coeff - Example 4

**Example:** Find the general solution to:

$$y'' - y' - 6y = e^{2t} + e^{3t}$$

## Mechanical Vibrations

While second-order differential equations with constant coefficients offers a narrow scope of differential equations, studying them is important because they serve as models of many important applications.

We will study motion of a mass on a spring, as its theory is applicable to other real world scenerios.

We will consider a mass hanging vertically from a spring, stretching it downward. When the mass-spring system is in equilibrium, the mass has two forces acting on it

Since the mass is in equilibrium, we know that the sum of these forces is 0. That is:

$$mg - kL = 0$$

Or, re-writing,  $mg = kL$

Images used were adapted from images created by user Siyo on Wikipedia

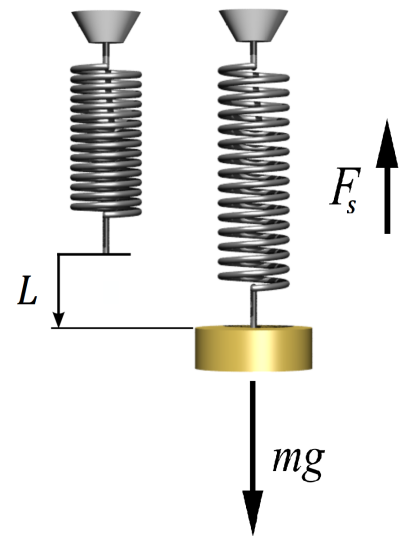

## Mechanical Vibrations

There is not much to study if we leave our mass-spring in equilibrium.

Suppose we stretch the mass from equilibrium by length  $u$  and set it in motion.

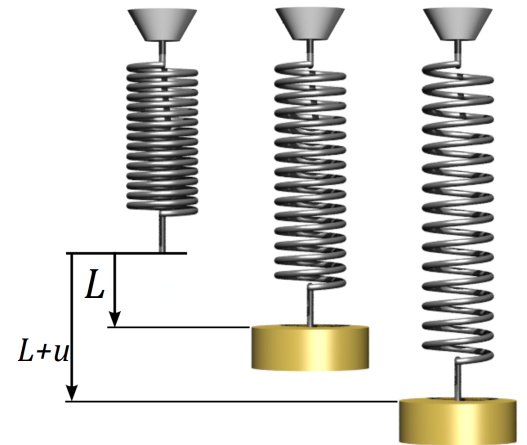

## Mechanical Vibrations - Undamped Case

We studied the motion of a mass on a spring and found that the position of the mass,  $u(t)$ , could be modeled by the differential equation:

$$mu'' + \gamma u' + ku = 0$$

Where  $m$  is the mass,  $\gamma$  is the damping coefficient, and  $k$  is the spring constant.

We will look at the undamped case, where  $\gamma = 0$

In the undamped case, the differential equations reduces to:

$$mu'' + ku = 0$$

Let's solve this diff. eq. to understand the mass's motion in this case.

## Mechanical Vibrations - Undamped Case

In the undamped case, the position of a mass on a spring is modeled by:

$$mu'' + ku = 0$$

The solutions, in terms of  $\omega_o = \sqrt{\frac{k}{m}}$  and constants  $A, B$  are:

$$u(t) = A \cos(\omega_o t) + B \sin(\omega_o t)$$

Since  $\cos(\omega_o t)$  and  $\sin(\omega_o t)$  are both periodic functions with a period of  $\frac{2\pi}{\omega_o}$ , it follows that  $u(t)$  is a periodic function with period  $\frac{2\pi}{\omega_o}$ , where  $\omega_o$  is called the natural frequency.

It can be useful to write this solution as a single periodic function.



### Mechanical Vibrations - Undamped Example

**Example:** Consider a mass weighing 16 lb that elongates a spring by 2 feet. We stretch it an additional 1 foot and set it in motion with an initial velocity of  $2\text{ft}/\text{sec}$ , causing the mass to oscillate up and down without damping. Let  $u(t)$  be the position in feet of the mass  $t$  seconds after it is released.

Set up the IVP modeling the position of the mass and solve it to find  $u(t)$ . Then find the amplitude of  $u(t)$

Example: Find the Solution of the IVP:

$$u'' + 16u = 0 \quad \text{with } u(0) = 1 \text{ and } u'(0) = 2$$

### Mechanical Vibrations - Example

**Example:** Consider a mass weighing 64 lb that elongates a spring by 4 feet. We stretch it an additional 15 inches and let it go, causing the position of the mass to oscillate up and down with a damping coefficient of  $\gamma = 8 \text{ lb} - \text{sec}/\text{ft}$ . Let  $u(t)$  be the position in feet of the mass  $t$  seconds after it is released.

Set up the IVP modeling the position of the mass and solve it to find  $u(t)$ .

## Mechanical Vibrations - Example

**Example:** Find the Solution of the IVP:

$$2u'' + 8u' + 16u = 0 \text{ with } u(0) = 1.25 \text{ and } u'(0) = 0$$

We can analyze our solution further:

$$u = 1.25e^{-2t} \cdot \cos(2t) + 1.25e^{-2t} \cdot \sin(2t)$$

Notice that we can factor out  $e^{-2t}$  to get:

$$u = e^{-2t} \cdot (1.25\cos(2t) + 1.25\sin(2t))$$

## Mechanical Vibrations - Damping Analysis

Now that we have done an example modeling a spring-mass system, let's look at the differential equation with parameters  $m > 0$ ,  $\gamma \geq 0$ ,  $k > 0$ :

$$mu'' + \gamma u' + ku = 0$$

We can solve this by looking at the characteristic equation:  $mr^2 + \gamma r + k = 0$

We can find the roots using the quadratic formula:  $r_{1,2} = \frac{-\gamma \pm \sqrt{\gamma^2 - 4mk}}{2m}$

The roots of the characteristic equation are given by:  $r_{1,2} = \frac{-\gamma \pm \sqrt{\gamma^2 - 4mk}}{2m}$

Case 2  $\gamma^2 - 4mk < 0$ : The general solution is:  $u = c_1 e^{\frac{-\gamma}{2m}t} \sin(\mu t) + c_2 e^{\frac{-\gamma}{2m}t} \cos(\mu t)$

where  $\mu = \frac{\sqrt{4mk - \gamma^2}}{2m}$  is the imaginary part of the roots.

So far, we have studied the case of a mass-spring system w/ no outside forces acting on it

However, there could be an outside force, given by the function  $g(t)$ , acting on the mass.

In this case, the differential equation modeling the position of the mass,  $u(t)$ , is given by

$$mu'' + \gamma u' + ku = g(t)$$



## Forced Mechanical Vibrations - Resonance

Consider the class of undamped oscillators with a periodic forcing function:

$$mu'' + ku = F_o \cos(\omega t) \text{ with } F_o = F(0). \text{ the initial force}$$

where  $\omega$  is the frequency of the forcing function.

To find solutions to this nonhomogeneous diff. eq., we first look at the associated homogenous diff. eq.:

$$mu'' + ku = 0$$

We found the solutions, in terms of  $\omega_o = \sqrt{\frac{k}{m}}$  and constants  $c_1, c_2$  are:

$$u(t) = c_1 \cos(\omega_o t) + c_2 \sin(\omega_o t)$$

## Introduction to Laplace Transformations

Thus far, most of our theory and techniques of solving differential equations has relied on the functions involved being continuous.

However, for some applications we may have discontinuous functions involved.

So, we will need different techniques for solving such differential equations.

The method we will learn is the method of Laplace Transformations.

Integrals have a smoothing effect on functions. For example, when we differentiate the continuous function  $y = |x|$  we get a discontinuous function:

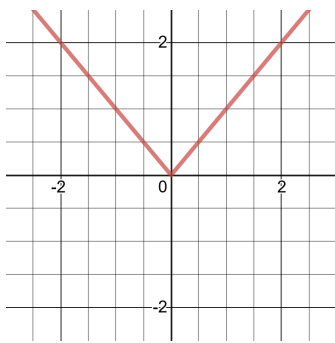

Figure:  $y = |x|$

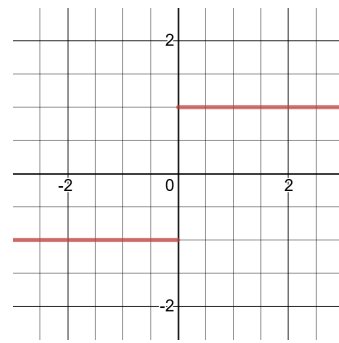

Figure:  $y' = \frac{d}{dx}(|x|)$

In reverse, integrating  $y'$  would smooth out that discontinuity.

Note: While the motivation for Laplace Transforms is to be able to solve differential equations involving discontinuous functions, it can be used to solve many differential equations.

We begin by defining the Laplace transform for a function  $f(t)$

We write the Laplace Transform as  $F(s) = \mathcal{L}\{f(t)\}$ , and it is defined as:

$$\mathcal{L}\{f(t)\} := \int_0^{\infty} e^{-st} \cdot f(t) dt$$

Since this is an improper integral,  $F(s)$  is only defined at values of  $s$  so that the integral converges.

**Theorem:** Suppose that  $f$  is a piecewise continuous function and there exist constants  $K$ ,  $a$ , and  $M$  such that  $f(t)$  is bound by:

$$|f(t)| \leq Ke^{at} \text{ for } t \geq M$$

then  $F(s) = \mathcal{L}\{f(t)\}$  exists for  $s > a$

## Computation of Laplace Transformations of 1

We will compute the Laplace transform of  $f(t) = 1$

$$\mathcal{L}\{1\} = \int_0^{\infty} e^{-st} \cdot 1 dt$$

## Computation of Laplace Transformations of $e^{at}$

We will compute the Laplace transform of  $f(t) = e^{at}$

$$\mathcal{L}\{e^{at}\} = \int_0^{\infty} e^{-st} \cdot e^{at} dt$$

## Computation of Laplace Transformations of $t$

We will compute the Laplace transform of  $f(t) = t$

$$\mathcal{L}\{t\} = \int_0^{\infty} e^{-st} \cdot t dt$$

## Computation of Laplace Transformations of $\sin(\alpha t)$

We will compute the Laplace transform of  $f(t) = \sin(\alpha t)$

$$\mathcal{L}\{\sin(\alpha t)\} = F(s) = \int_0^{\infty} e^{-st} \cdot \sin(\alpha t) dt$$

## Laplace Transformations of a discontinuous function

We will compute the Laplace transform of the discontinuous function:

$$f(t) = \begin{cases} 1 & t \leq 3 \\ 0 & t > 3 \end{cases}$$

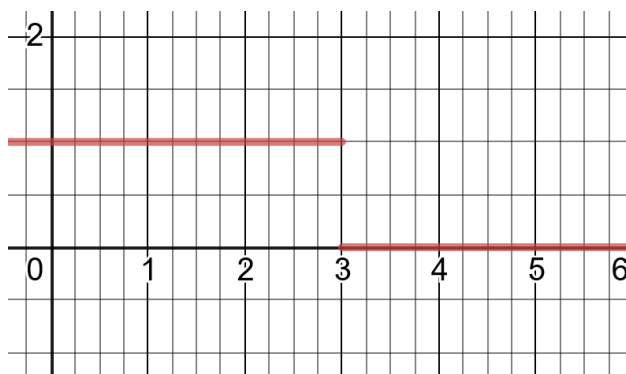

$$\mathcal{L}\{f(t)\} = \int_0^{\infty} e^{-st} \cdot f(t) dt$$



In working with Laplace Transforms, and differential equations in general, we often have more than one term involved.

So, we want to be able to compute the Laplace Transform of linear combinations of functions.

i.e. for functions,  $f_1(t)$  and  $f_2(t)$  with constants  $c_1$  and  $c_2$ , we want to compute:

$$\mathcal{L}\{c_1 \cdot f_1(t) + c_2 \cdot f_2(t)\} =$$

## Linearity of Laplace Transformations

**Example:** Compute the Laplace Transform:

$$\mathcal{L}\{-2 \cdot t + 3 \cdot e^{2t}\}$$

## Differential Equations with Laplace Transformations

Now that we've defined the Laplace Transform and computed it for some functions, we will look at how to solve differential equations using them.

The defining trait of a differential equation is that it involves a derivative.

So, we need to understand the Laplace Transform of a derivative.

$$\mathcal{L} \left\{ \frac{dy}{dt} \right\}$$

**Example:** Find the solution of the Initial Value Problem:

$$y' = 3y \quad \text{with } y(0) = 4$$

We saw that we can use Laplace Transforms to solve an Initial Value Problem.

Let's take a look at this process with a generic differential equation:

$$\frac{dy}{dt} = f(t, y)$$

We saw earlier that the Laplace Transform of  $y'$  is:

$$\mathcal{L}\{y'\} = s \cdot \mathcal{L}\{y\} - y(0)$$

What about higher order differential equations?

We will use what we know about  $\mathcal{L}\{y'\}$  to find  $\mathcal{L}\{y''\}$

Since  $y'' = (y')'$  we can compute it's Laplace Transform as:

We saw earlier that the Laplace Transform of  $y(t) = \sin(\alpha t)$  is:

$$\mathcal{L}\{\sin(\alpha t)\} = \frac{\alpha}{s^2 + \alpha^2}$$

We can find the Laplace Transform of  $\cos(\alpha t)$  in a similar fashion (recall that it required integration by parts twice).

Instead, we will use what we know about  $\mathcal{L}\{\sin(\alpha t)\}$  to find  $\mathcal{L}\{\cos(\alpha t)\}$  in a clever way.

We will use that  $y(t) = \sin(\alpha t)$  satisfies the differential equation:

$$y' = \alpha \cos(\alpha t) \text{ with } y(0) = \sin(\alpha \cdot 0) = 0$$

## 2nd Order Diff Eq with Laplace Ex 1

**Example:** Solve the initial value problem:

$$y'' + y' - 12y = 0 \text{ with } y(0) = 2 \text{ and } y'(0) = 1$$



## 2nd Order Diff Eq with Laplace Ex 2

**Example:** Solve the initial value problem:

$$y'' + y = e^{2t} \quad \text{with } y(0) = 0 \text{ and } y'(0) = 0$$

## Introduction to Step Functions

We motivated the need for the Method of Laplace Transforms in solving Diff. Eq. by the fact that our older methods failed for discontinuous functions.

Here, we will define a basic discontinuous function: the Step Function

We define the step function,  $u_c(t)$  in the following way:

$$u_c(t) = \begin{cases} 0 & t < c \\ 1 & t \geq c \end{cases}$$

## Modifications to Step Functions

We can make modifications to  $u_c(t)$  to build other discontinuous functions

$$u_c(t) = \begin{cases} 0 & t < c \\ 1 & t \geq c \end{cases}$$

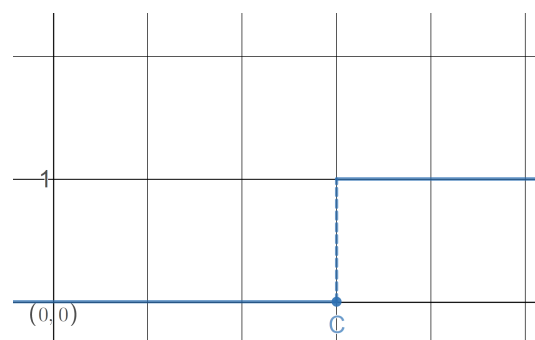

To reverse our step function to "step down", how should we change  $u_c(t)$ ?

$$\begin{cases} 1 & t < c \\ 0 & t \geq c \end{cases}$$

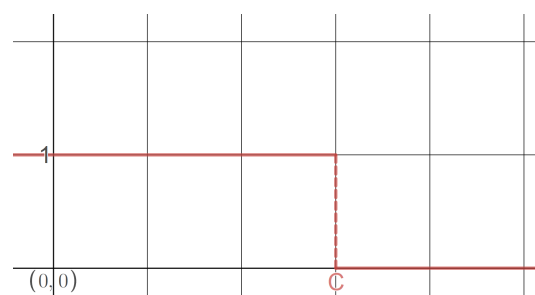

## Modifications to Step Functions

We can make modifications to  $u_c(t)$  to build other discontinuous functions

$$u_c(t) = \begin{cases} 0 & t < c \\ 1 & t \geq c \end{cases}$$

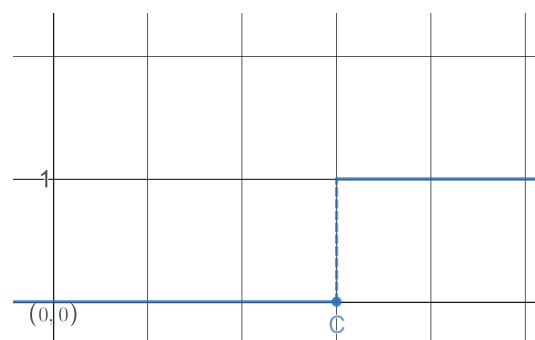

To step up then back down, how should we change  $u_c(t)$ ?

$$\begin{cases} 0 & t < c \\ 1 & c < t \leq d \\ 0 & t \geq d \end{cases}$$

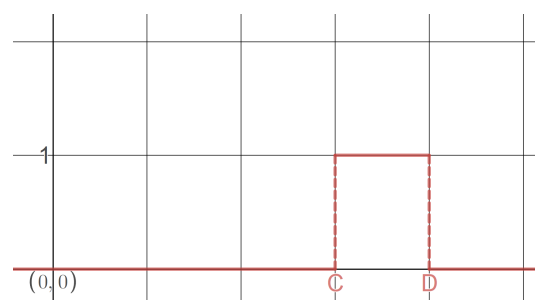

## Modifications to Step Functions

We can make modifications to  $u_c(t)$  to build other discontinuous functions

$$u_c(t) = \begin{cases} 0 & t < c \\ 1 & t \geq c \end{cases}$$

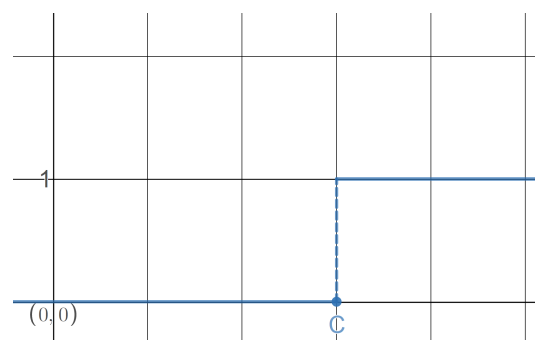

To scale our step, how should we change  $u_c(t)$ ?

$$\begin{cases} 0 & t < c \\ 2 & t \geq c \end{cases}$$

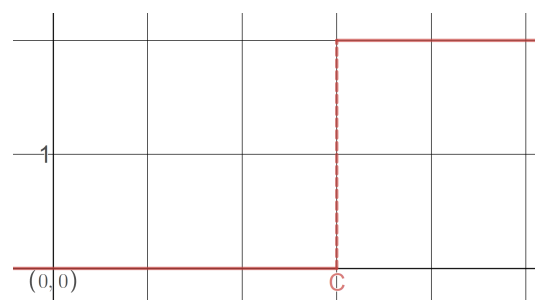

## Modifications to Step Functions

We can make modifications to  $u_c(t)$  to build other discontinuous functions

$$u_c(t) = \begin{cases} 0 & t < c \\ 1 & t \geq c \end{cases}$$

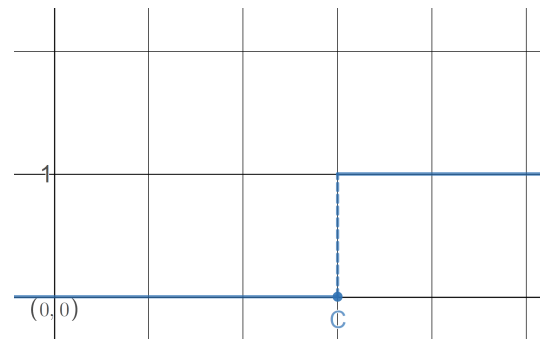

We can, also, take combinations of these changes, such as having a function that steps up by 2 then back down to 1. How can we build this from step functions?

$$\begin{cases} 0 & t < c \\ 2 & c < t \leq d \\ 1 & t \geq d \end{cases}$$

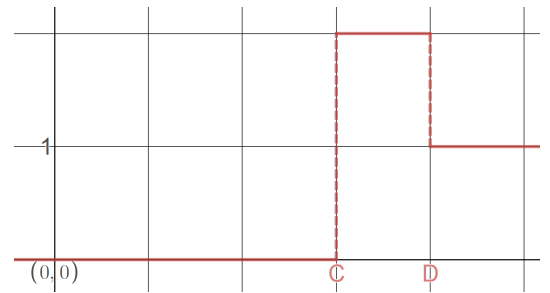

### Shifted Functions

Suppose we have a function  $f(t)$  modeling a particular process starting at  $t = 0$ .

Now suppose that we wait to start this process until  $t = c$

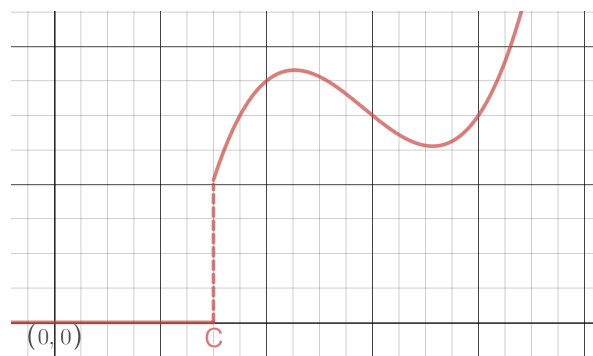
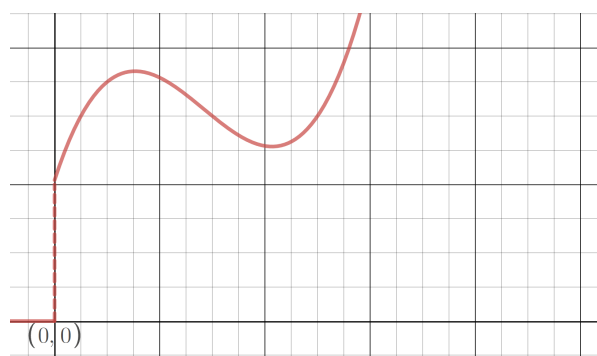

## Laplace Transformations of a shifted step function

We will compute the Laplace transform of the shifted function:

$$u_c(t)f(t - c)$$

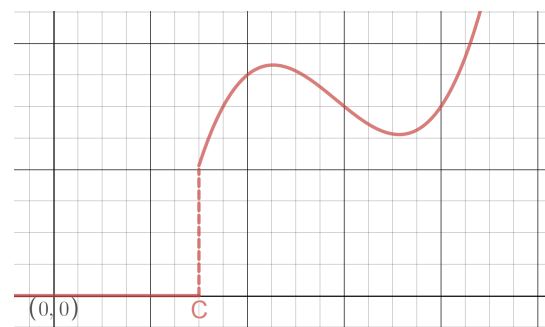



## Laplace Transform of a shifted step function - Ex 1

**Example:** Compute the Laplace Transform of:

$$\mathcal{L}\{u_2(t) \cdot \sin(3t - 6)\}$$

## Inverse Laplace Transform - Ex 1

**Example:** Compute the Inverse Laplace Transform of:

$$F(s) = \frac{e^{-4s} + 1}{s - 2}$$

$$\mathcal{L}^{-1} \left\{ \frac{e^{-4s} + 1}{s - 2} \right\}$$

## Inverse Laplace Transform - Ex 2

**Example:** Compute the Inverse Laplace Transform of:

$$F(s) = \frac{3e^{-3s}}{s^2 + 4}$$

$$\mathcal{L}^{-1} \left\{ \frac{3e^{-3s}}{s^2 + 4} \right\}$$

## Laplace Transform of $e^{ct} \cdot f(t)$

In general, we can't compute the Laplace of a product of functions:  $f(t) \cdot g(t)$

We are, however, able to compute the Laplace of a product for certain functions.

Here, we will look at the product where one of the functions is  $e^{ct}$

That is, we will compute the Laplace Transform of:

$$\mathcal{L}\{e^{ct} \cdot f(t)\}$$

## Laplace Transform of $e^{ct} \cdot f(t)$

**Example:** Compute the Inverse Laplace Transform of:

$$G(s) = \frac{1}{s^2 + 2s + 2}$$

## Solving a discontinuous Differential Equation

**Example:** Solve the Initial Value Problem

$$y'' + 2y' + 2y = u_2(t) \text{ with } y(0) = 0 \text{ and } y'(0) = 1$$

## Solving a discontinuous Differential Equation

**Example:** Solve the Initial Value Problem

$$y'' + 2y' + 2y = u_2(t) \text{ with } y(0) = 0 \text{ and } y'(0) = 1$$

We need to find the Inverse Laplace of:

$$\mathcal{L}\{y\} = \frac{1}{s^2+2s+2} + e^{-2s} \cdot \frac{1}{s(s^2+2s+2)}$$

## Solving a discontinuous Step Functions

**Example:** Solve the Initial Value Problem

$$y' + 4y = u_2(t) \cdot \sin(3t - 6) \text{ with } y(0) = 0$$



## Definition of Dirac Delta Function

We looked at functions with discontinuities when we studied **step functions**.

Step functions are good for modeling a process that suddenly "turns on", like an electrical switch.

However, in some scenarios a large force can be applied in a short time, like an electrical surge.

To model this, we define a function  $g(t)$  that is over a short interval centered around some time  $t = 0$ :  $-\tau < t < \tau$  for a small  $\tau > 0$ . This function depends on  $\tau$ , so we'll write  $g(t) = d_\tau(t)$ .

### Definition of Dirac Delta Function

$$g(t) = d_{\tau}(t) = \begin{cases} \frac{1}{2\tau} & -\tau < t < \tau \\ 0 & \text{otherwise} \end{cases}$$

$$I(\tau) = \int_{-\tau}^{\tau} g(t) dt = 1 \text{ for every } \tau$$

## Definition of Dirac Delta Function

We define  $\delta(t)$  to be a function with the properties:

$$\delta(t) = 0, \text{ for } t \neq 0$$

$$\int_{-\infty}^{\infty} \delta(t) dt = 1$$

## Integration of the Dirac Delta Function

We defined the generalized Dirac Delta Function as:

$$\delta(t - t_o) = 0, \text{ for } t \neq t_o \quad \int_{-\infty}^{\infty} \delta(t - t_o) dt = 1$$

We can visualize  $\delta(t - t_o)$  as the limit as  $\tau \rightarrow 0$  of:

$$d_{\tau}(t - t_o) = \begin{cases} \frac{1}{2\tau} & t_o - \tau < t < t_o + \tau \\ 0 & \text{otherwise} \end{cases}$$

For a function,  $f(t)$ , we will compute:

$$\int_{-\infty}^{\infty} \delta(t - t_o) \cdot f(t) dt$$

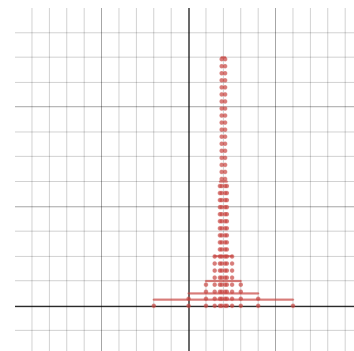

## Laplace Transform of the Dirac Delta Function

We saw that for a function  $f(t)$ :

$$\int_{-\infty}^{\infty} \delta(t - t_0) \cdot f(t) dt = f(t_0)$$

We will use this to compute the Laplace transform of  $\delta(t - t_0)$ :

$$\mathcal{L}\{\delta(t - t_0)\} =$$

## Solving a discontinuous Differential Equation

**Example:** Solve the Initial Value Problem

$$y'' + 6y' + 25y = \delta(t - 2) \text{ with } y(0) = 0 \text{ and } y'(0) = 0$$

In some applications, we may need our model to track multiple variables that depend on a single independent variable.

We have discussed population models of a species.

We could have two species whose populations change over time, but are impacted by each other.

The most common application of this is a Predator-Prey model where one species relies on the other for food.

Consider the population of rabbits and foxes, represented by  $x(t)$  and  $y(t)$ , respectively.

For positive values  $a, c, \alpha, \gamma$

$$\frac{dx}{dt} = ax - \alpha xy$$

$$\frac{dy}{dt} = -cy + \gamma xy$$

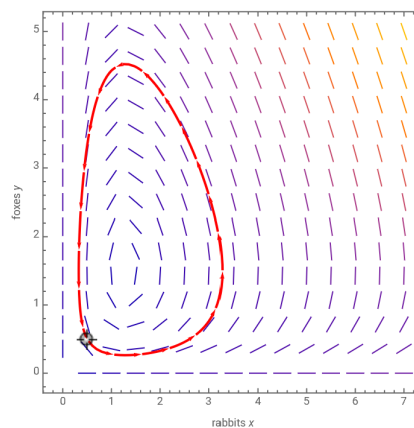

In general, for a set of  $n$  functions  $x_1(t), \dots, x_n(t)$ , a System of Differential Equations for  $x_i$ 's is given by:

$$x_1'(t) = F_1(t, x_1, x_2, \dots, x_n)$$

$$x_2'(t) = F_2(t, x_1, x_2, \dots, x_n)$$

$\vdots$

$$x_n'(t) = F_n(t, x_1, x_2, \dots, x_n)$$



## Linear vs. Non-Linear Systems of Diff. Eq.

For single differential equations of the form:  $y'(t) = F(t, y)$

We call a diff. eq. *linear* if it could be written as:

$$y'(t) = p(t) \cdot y + g(t)$$

Similarly, we call a system of diff. eq.'s *linear* if it can be written in the form:

$$x_1'(t) = p_{11}(t)x_1 + \cdots + p_{1n}(t)x_n + g_1(t)$$

$$x_2'(t) = p_{21}(t)x_1 + \cdots + p_{2n}(t)x_n + g_2(t)$$

$\vdots$

$$x_n'(t) = p_{n1}(t)x_1 + \cdots + p_{nn}(t)x_n + g_n(t)$$

Ex: The system of differential equations:

$$x_1'(t) = t^2x_1 + (3 - t)x_2 + \ln(t)x_3 + 6t$$

$$x_2'(t) = \cos(4t)x_1 + 2tx_2 + t^3x_3 - 5$$

$$x_3'(t) = \sin(t)x_1 + \frac{1}{t}x_2 + \sqrt{t}x_3$$

is a linear system of differential equations.

Recall that we define the *order* of a differential equation as the highest derivative that arises in the differential equation.

Consider the spring-mass application that can model the position,  $u(t)$ , of a mass on a spring by the second order differential equation:

$$mu'' + \gamma u' + ku = F(t)$$

**Recall** that a system of diff. eq. of two functions is linear if it can be written as:

$$x' = p_{11}(t) \cdot x + p_{12}(t) \cdot y + g_1(t)$$

$$y' = p_{21}(t) \cdot x + p_{22}(t) \cdot y + g_2(t)$$

## Operations with Matrices

We will need to learn some operations of matrices to proceed with our study of Linear Systems of Diff. Eq. with constant coefficients.

We will write a generic  $n \times n$  matrix as:  $A = \begin{pmatrix} a_{11} & a_{12} & \cdots & a_{1n} \\ a_{21} & a_{22} & \cdots & a_{2n} \\ \vdots & \vdots & \cdots & \vdots \\ a_{n1} & a_{n2} & \cdots & a_{nn} \end{pmatrix}$

## Operations with Matrices

When we are *Adding* two matrices  $A$  and  $B$ , they must be the same size. That is,  $A$  and  $B$  must have the same number of rows and columns.

$$A + B = \underbrace{\begin{pmatrix} a_{11} & a_{12} & \cdots & a_{1n} \\ a_{21} & a_{22} & \cdots & a_{2n} \\ \vdots & \vdots & \ddots & \vdots \\ a_{n1} & a_{n2} & \cdots & a_{nn} \end{pmatrix}}_A + \underbrace{\begin{pmatrix} b_{11} & b_{12} & \cdots & b_{1n} \\ b_{21} & b_{22} & \cdots & b_{2n} \\ \vdots & \vdots & \ddots & \vdots \\ b_{n1} & b_{n2} & \cdots & b_{nn} \end{pmatrix}}_B$$

Notice that the entry in the  $i^{\text{th}}$  row and  $j^{\text{th}}$  column of the matrix  $A + B$ , which we write as  $(A + B)_{ij}$ , is given by:

Example:  $\begin{pmatrix} 1 & 2 \\ 3 & 4 \end{pmatrix} + \begin{pmatrix} 3 & 8 \\ 6 & -2 \end{pmatrix}$

Multiplication with Matrices depends on what we multiply the Matrix with

We can multiply a Matrix with a scalar, a vector, or another matrix.

We will start with Multiplication of a Matrix with a scalar.

For the constant scalar  $c$  and the matrix  $A$ , we define multiplication:

$$c \cdot A = c \cdot \begin{pmatrix} a_{11} & a_{12} & \cdots & a_{1n} \\ a_{21} & a_{22} & \cdots & a_{2n} \\ \vdots & \vdots & \ddots & \vdots \\ a_{n1} & a_{n2} & \cdots & a_{nn} \end{pmatrix}$$

Multiplication with Matrices depends on what we multiply the Matrix with

For a Matrix,  $A$ , and a vector  $\vec{v}$  we define multiplication:

$$A\vec{v} = \begin{pmatrix} a_{11} & a_{12} & \cdots & a_{1n} \\ a_{21} & a_{22} & \cdots & a_{2n} \\ \vdots & \vdots & \ddots & \vdots \\ a_{n1} & a_{n2} & \cdots & a_{nn} \end{pmatrix} \begin{pmatrix} v_1 \\ v_2 \\ \vdots \\ v_n \end{pmatrix}$$

**Example:**  $\begin{pmatrix} 1 & 2 \\ 3 & 4 \end{pmatrix} \cdot \begin{pmatrix} 3 \\ 6 \end{pmatrix}$

Multiplication with Matrices depends on what we multiply the Matrix with

For a Matrix,  $A$ , and another Matrix,  $B$ , we define multiplication:

$$A \cdot B = \begin{pmatrix} a_{11} & a_{12} & \cdots & a_{1n} \\ a_{21} & a_{22} & \cdots & a_{2n} \\ \vdots & \vdots & \ddots & \vdots \\ a_{n1} & a_{n2} & \cdots & a_{nn} \end{pmatrix} \cdot \begin{pmatrix} b_{11} & b_{12} & \cdots & b_{1n} \\ b_{21} & b_{22} & \cdots & b_{2n} \\ \vdots & \vdots & \ddots & \vdots \\ b_{n1} & b_{n2} & \cdots & b_{nn} \end{pmatrix}$$

Example:

$$\begin{pmatrix} 1 & 2 \\ 3 & 4 \end{pmatrix} \begin{pmatrix} 3 & 8 \\ 6 & -2 \end{pmatrix}$$



Note 1: Unlike with numbers, the order in which we multiply Matrices matters.

Note 2: There is a number, 1, that can be multiplied by any number and the number doesn't change.

In other words,  $1 \cdot x = x = x \cdot 1$  for any number,  $x$

Note 3: Multiplications by a scalar  $c$  is equivalent to multiplying by  $c \cdot I$ .

## Self-Operations with Matrices

We just discussed the operations of adding two matrices and multiplying a matrix with either another matrix, a vector, or a scalar.

Some operations of matrices do not involve a second value.

Example: 
$$\overline{\begin{pmatrix} 1 + i & 3 - 2i \\ 3 - i & 4 + 3i \end{pmatrix}}$$

## Self-Operations with Matrices

Another self operation of a matrix,  $A$ , is called the transposition, we denote  $A^T$

The entries of the transposed matrix,  $A^T$ , can be found by changing the positions of the entries so that:

$$(A)_{ij} = (A^T)_{ji}$$

**Example:** For the Matrix  $A = \begin{pmatrix} 1 & 2 \\ 3 & 4 \end{pmatrix}$  we can compute the transpose as:

$$\begin{pmatrix} 1 & 2 \\ 3 & 4 \end{pmatrix}^T$$

For scalar numbers, our four basic functions are addition, subtraction, multiplication, and division.

We can understand subtraction as adding the negative: e.g.  $6 - 3 = 6 + (-3)$

We can, also, understand division as multiplying by the inverse: e.g.  $6 \div 3 = 6 \cdot \frac{1}{3}$

## Inverse and Determinant of a Matrices

Since some matrices are invertible and some are not, it will be helpful to have a way of determining this.

The *determinant* of a matrix, written  $\det(A)$ , gives us a way of telling whether or not a matrix,  $A$ , is invertible

The *determinant* of a matrix is defined for any  $n \times n$  matrix, though for our course we will restrict our study to  $2 \times 2$  matrices.

The determinant of the matrix can be found computationally:

$$\det \begin{pmatrix} a & b \\ c & d \end{pmatrix}$$

**Example:** Compute the determinant:

$$\det \begin{pmatrix} 2 & 1 \\ 6 & -3 \end{pmatrix}$$

We motivated our conversation about Matrices as a way to understand Linear Systems of differential equations.

As we said earlier, for this course we will focus on homogeneous Linear Systems with constant coefficients, which have the form:

$$\begin{aligned}x' &= a \cdot x + b \cdot y \\y' &= c \cdot x + d \cdot y\end{aligned}$$

We will now use our understanding of matrices to recast these systems of differential equations.

$$\text{Let } \vec{Y} = \langle x, y \rangle = \begin{pmatrix} x \\ y \end{pmatrix} \text{ and } A = \begin{pmatrix} a & b \\ c & d \end{pmatrix}$$

$$A \cdot \vec{Y} = \begin{pmatrix} a & b \\ c & d \end{pmatrix} \cdot \begin{pmatrix} x \\ y \end{pmatrix}$$

So, we can rewrite the system of differential equations:

$$\begin{aligned}x' &= a \cdot x + b \cdot y \\y' &= c \cdot x + d \cdot y\end{aligned}$$







## Solutions of a Linear System

Consider the Linear System of Differential Equations:

$$\begin{aligned}x' &= 5x - 2y \\ y' &= -x + 4y\end{aligned}$$

$$\Leftrightarrow \vec{Y}' = \begin{pmatrix} 5 & -2 \\ -1 & 4 \end{pmatrix} \vec{Y} \text{ where } \vec{Y} = \begin{pmatrix} x \\ y \end{pmatrix}$$

At the point  $(x, y) = (1, 2)$  the tangent vector is given by:

$$\vec{Y}' = \begin{pmatrix} 5 & -2 \\ -1 & 4 \end{pmatrix} \begin{pmatrix} 1 \\ 2 \end{pmatrix}$$

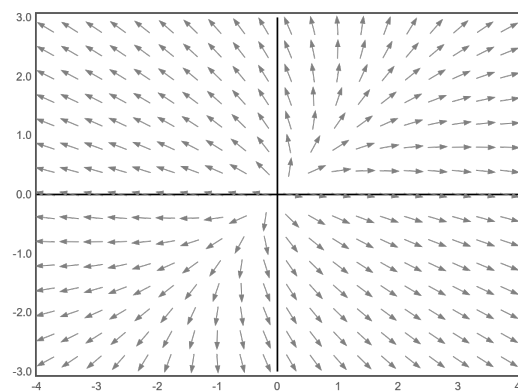
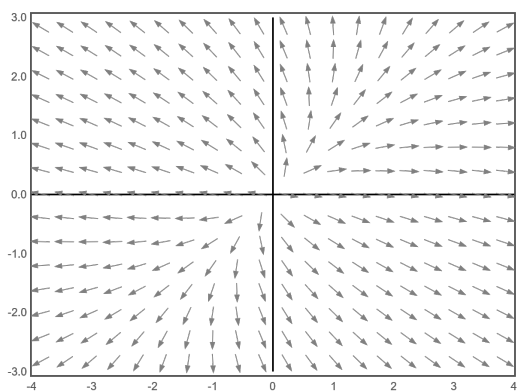

### Straight Line Solutions of a Linear System

We saw that we could sketch solutions to Linear Systems of differential equations given by  $\vec{Y}' = A\vec{Y}$  using a direction field

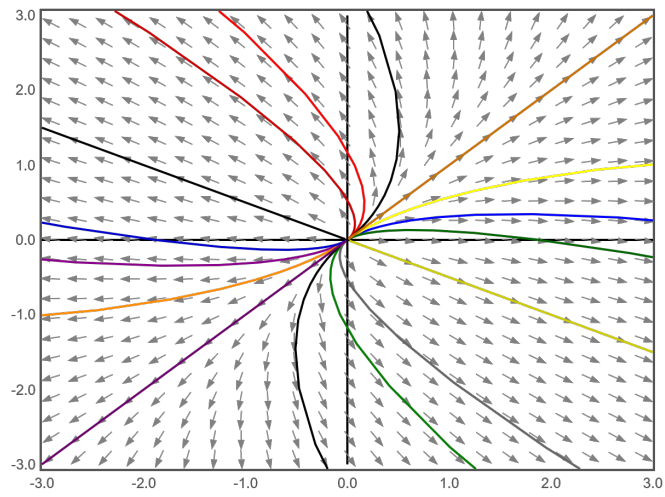

We saw that that straight-line solutions, such that  $\vec{Y}' = \lambda \vec{Y}$  for a constant  $\lambda$ , to Linear Systems of differential equations, given by  $\vec{Y}' = A \cdot \vec{Y}$ , satisfy:

$$A \cdot \vec{Y} = \lambda \vec{Y}$$

For us to find these straight-line solutions,  $\vec{Y}$ , we first need to understand how to solve Linear equations of the form:

$$A\vec{x} = \vec{b}$$

for an unknown vector  $\vec{x}$  and known vector  $\vec{b}$  with a matrix  $A$

## Eigenvalues and Vectors

We saw that that straight-line solutions, such that  $\vec{Y}' = \lambda \vec{Y}$  for a constant  $\lambda$ , to Linear Systems of differential equations, given by  $\vec{Y}' = A \cdot \vec{Y}$ , satisfy:

$$A \cdot \vec{Y} = \lambda \vec{Y}$$

We, also, found that if  $\det(A) \neq 0$  then the only solution of  $A \cdot \vec{x} = \vec{0}$  is  $\vec{x} = \vec{0}$

We will start by giving a definition to constants,  $\lambda$ , and vectors,  $\vec{v}$ , that satisfy the above equation we found to be true for straight-line solutions:  $A \cdot \vec{v} = \lambda \vec{v}$

**Definition:** We call  $\lambda$  an *eigenvalue* with *eigenvector*  $\vec{v} \neq \vec{0}$  if  $A \cdot \vec{v} = \lambda \vec{v}$

## Eigenvalues and Vectors

**Definition:** We call  $\lambda$  an *eigenvalue* with *eigenvector*  $\vec{v} \neq \vec{0}$  if  $A \cdot \vec{v} = \lambda \vec{v}$

**Conclusion:** If  $\lambda$  is an eigenvalue of  $A$  then  $\det(A - \lambda I) = 0$

For a  $2 \times 2$  matrix  $A = \begin{pmatrix} a & b \\ c & d \end{pmatrix}$  this means that:

$$\det \begin{pmatrix} a - \lambda & b \\ c & d - \lambda \end{pmatrix} = \det(A - \lambda I) = 0$$

$\lambda^2 - (a + d)\lambda + (ad - bc) = 0$  is called the *characteristic equation* of  $A$

## Eigenvalues and Vectors Example

**Example:** Find the eigenvalue(s) and eigenvector(s) of:

$$A = \begin{pmatrix} 5 & -2 \\ -1 & 4 \end{pmatrix}$$

## Linearly Independent Vectors

Our study of Linear Systems of Differential Equations has relied on theory from Linear Algebra.

We will need one more definition and result from Linear Algebra to find the General Solution to a system of differential equations.

**Definition:** A set of  $k$  vectors  $\vec{x}_1, \vec{x}_2, \dots, \vec{x}_k$  are called *linearly dependent* if there exists a set of constants  $c_1, c_2, \dots, c_k$  with  $c_i \neq 0$  for at least one  $1 \leq i \leq k$  so that:

$$c_1\vec{x}_1 + c_2\vec{x}_2 + \dots + c_k\vec{x}_k = 0$$

The General Solution of a Linear System of Diff. Eq.

Studying the direction field and phase portrait of the Linear System of Diff Eq:

$$\vec{Y}' = A\vec{Y} \text{ where } \vec{Y} = \begin{pmatrix} x \\ y \end{pmatrix} \text{ and } A = \begin{pmatrix} 5 & -2 \\ -1 & 4 \end{pmatrix}$$

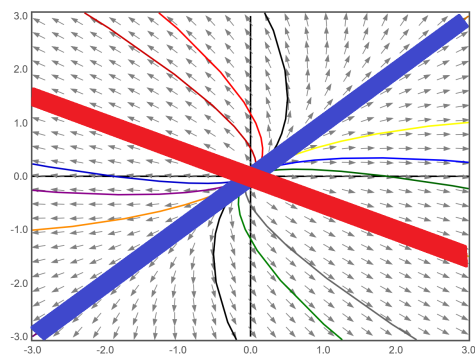

we noticed two straight-line solutions.



## The General Solution of a Linear System of Diff. Eq.

**Theorem:** Principle of Superposition

If  $\vec{Y}_1(t)$  and  $\vec{Y}_2(t)$  are solutions to the Linear System of Differential Equations:

$$\vec{Y}' = A\vec{Y}$$

then for any constants  $c_1$  and  $c_2$ :

$$Y(t) = c_1 \vec{Y}_1(t) + c_2 \vec{Y}_2(t)$$

is also a solution.

**Theorem:** If  $\vec{Y}_1(t), \dots, \vec{Y}_n(t)$  are solutions to the Linear System of  $n$  Diff. Eq.:

$$\vec{Y}' = A\vec{Y}$$

and the set of vectors  $\vec{Y}_1(t_0), \dots, \vec{Y}_n(t_0)$  at a value  $t = t_0$  are linearly independent then:

$$\vec{Y}(t) = c_1 \vec{Y}_1(t) + \dots + c_n \vec{Y}_n(t) \text{ forms the General Solution.}$$

We looked for solutions to Linear Systems of Diff Eq. in the example:

$$\vec{Y}' = \begin{pmatrix} 5 & -2 \\ -1 & 4 \end{pmatrix} \cdot \vec{Y} \quad \text{where } \vec{Y} = \begin{pmatrix} x \\ y \end{pmatrix}$$

On the direction field and phase portrait, we noticed straight-line solutions

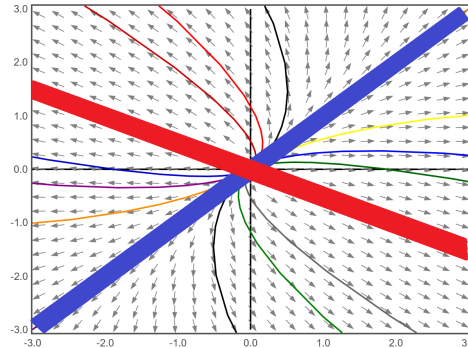

We observed that straight-line sol's are scalar multiples of the tangent vector  $\vec{Y}'$

That is, there are straight-line sol's,  $\vec{Y}_1(t)$  and  $\vec{Y}_2(t)$  so that  $\vec{Y}'_i(t) = \lambda_i \vec{Y}_i(t)$

We, also, saw that, for a 2-dimensional systems like this one, if we can find two linearly independent solutions then the General Solution is given by:

$$\vec{Y} = c_1 \vec{Y}_1(t) + c_2 \vec{Y}_2(t)$$

Since  $A$  has distinct eigenvalues, and thus the eigenvectors are linearly ind., if we find these two straight-line sol's then we can build the Gen. Sol.

For each  $\vec{Y}_i(t)$  we know that  $\vec{Y}_i(t) = f_i(t) \cdot \vec{v}_i$  and  $\vec{Y}'(t) = \lambda \vec{Y}(t)$

We found e-vecs,  $\vec{v}_i$ , thus we need to find  $f_i(t)$  to find  $\vec{Y}_i(t)$

So, we want to see if the differential equation is true for  $\vec{Y}_i = e^{\lambda_i t} \vec{v}_i$ :

$$\underbrace{\lambda_i e^{\lambda_i t} \vec{v}_i}_{\text{LHS}} = \left( e^{\lambda_i t} \right)' \vec{v}_i = \left( e^{\lambda_i t} \vec{v}_i \right)' \stackrel{!}{=} A \cdot e^{\lambda_i t} \vec{v}_i = e^{\lambda_i t} \cdot A \vec{v}_i = e^{\lambda_i t} \cdot \lambda_i \vec{v}_i = \underbrace{\lambda_i \cdot e^{\lambda_i t} \vec{v}_i}_{\text{RHS}}$$

Returning to our example to find solutions to the Linear Systems of Diff Eq.:

$$\vec{Y}' = \begin{pmatrix} 5 & -2 \\ -1 & 4 \end{pmatrix} \cdot \vec{Y} \quad \text{where } \vec{Y} = \begin{pmatrix} x \\ y \end{pmatrix}$$

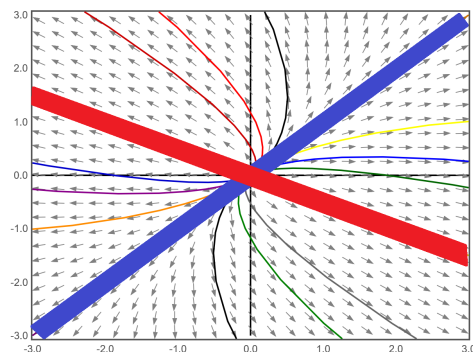

For a 2-dimensional systems like this one, if we can find two linearly independent solutions then the General Solution is given by:

$$\vec{Y} = c_1 \vec{Y}_1(t) + c_2 \vec{Y}_2(t)$$

Our example:

$$\vec{Y}' = \begin{pmatrix} 5 & -2 \\ -1 & 4 \end{pmatrix} \cdot \vec{Y} \quad \text{where } \vec{Y} = \begin{pmatrix} x \\ y \end{pmatrix}$$

can be written componentwise as:

$$\begin{aligned} x' &= 5x - 2y \\ y' &= -x + 4y \end{aligned}$$

We found the general solution:

$$\vec{Y}(t) = c_1 e^{3t} \begin{pmatrix} 1 \\ 1 \end{pmatrix} + c_2 e^{6t} \begin{pmatrix} -2 \\ 1 \end{pmatrix}$$

So, what are the scalar functions  $x(t)$  and  $y(t)$ ?

We have now seen an example in which we found the General Solution to a Linear System of Differential Equations of the form:

$$\vec{Y}' = A \cdot \vec{Y} \quad \text{where } \vec{Y} = \begin{pmatrix} x \\ y \end{pmatrix} \quad \text{and } A = \begin{pmatrix} a & b \\ c & d \end{pmatrix}$$

Let's recap that process in the case where  $A$  has distinct eigenvalues  $\lambda_1 \neq \lambda_2$

Note 1: The theory we covered changes the process of solving a system of diff eq into a Linear Algebra process of finding eigenvalues and eigenvectors.

Note 2: The solutions  $\vec{Y}_1 = e^{\lambda_1 t} \vec{v}_1$  and  $\vec{Y}_2 = e^{\lambda_2 t} \vec{v}_2$  correspond to the straight-line solutions in the phase plane.

**Example:** Find the General Solution of the Linear System of Diff. Eq. given by:

$$\vec{Y}' = \begin{pmatrix} 3 & -6 \\ -3 & 0 \end{pmatrix} \cdot \vec{Y} \quad \text{where } \vec{Y} = \begin{pmatrix} x \\ y \end{pmatrix}$$

## Phase Portrait of Systems from Example 2

In Example 2, we found that the General Solution to:

$$\vec{Y}' = \begin{pmatrix} 3 & -6 \\ -3 & 0 \end{pmatrix} \cdot \vec{Y} \quad \text{where } \vec{Y} = \begin{pmatrix} x \\ y \end{pmatrix}$$

in terms of constants  $c_1$  and  $c_2$  are:  $\vec{Y}(t) = c_1 e^{-3t} \begin{pmatrix} 1 \\ 1 \end{pmatrix} + c_2 e^{6t} \begin{pmatrix} -2 \\ 1 \end{pmatrix}$

The Phase Portrait shows sol's of the System of Diff. Eq. in the  $xy$ -plane.

Let's sketch the Phase Portrait using the Gen. Sol. we found.

To start, we know that when  $c_2 = 0$  the solution is:  $\vec{Y}_1(t) = c_1 e^{-3t} \begin{pmatrix} 1 \\ 1 \end{pmatrix}$

Similarly, when  $c_1 = 0$  the solution is:  $\vec{Y}_2(t) = c_2 e^{6t} \begin{pmatrix} -2 \\ 1 \end{pmatrix}$

Since these sol's give scalar multiples of the e-vecs, they give straight-line sol's

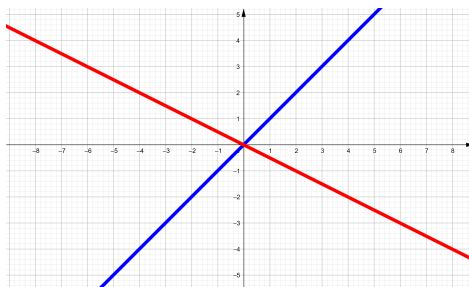



## Phase Portrait of Systems from Example 2

For the General Solution:  $\vec{Y}(t) = c_1 e^{-3t} \begin{pmatrix} 1 \\ 1 \end{pmatrix} + c_2 e^{6t} \begin{pmatrix} -2 \\ 1 \end{pmatrix}$

The Phase Portrait is given by:

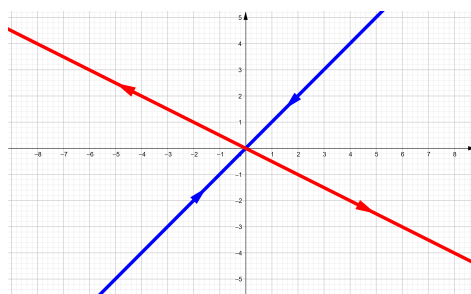

Along  $\vec{Y}_1$ , as  $t \rightarrow \infty$ ,  $e^{-3t} \rightarrow 0$  and thus  $\vec{Y}_1$  goes to the origin

Along  $\vec{Y}_2$ , as  $t \rightarrow \infty$ ,  $e^{6t} \rightarrow \infty$  and thus  $\vec{Y}_2$  becomes a larger multiple of  $\vec{v}_2$

What about the curves of the other solutions, where  $c_1 \neq 0$  and  $c_2 \neq 0$ ?

In our opening example, we found that the General Solution to:

$$\vec{Y}' = \begin{pmatrix} 5 & -2 \\ -1 & 4 \end{pmatrix} \cdot \vec{Y} \quad \text{where } \vec{Y} = \begin{pmatrix} x \\ y \end{pmatrix}$$

in terms of constants  $c_1$  and  $c_2$  are:  $\vec{Y}(t) = c_1 e^{3t} \begin{pmatrix} 1 \\ 1 \end{pmatrix} + c_2 e^{6t} \begin{pmatrix} -2 \\ 1 \end{pmatrix}$

Let's sketch the Phase Portrait using the Gen. Sol. we found.

Straight-line sol's are scalar multiples of e-vecs  $\vec{v}_1 = \begin{pmatrix} 1 \\ 1 \end{pmatrix}$  and  $\vec{v}_2 = \begin{pmatrix} -2 \\ 1 \end{pmatrix}$

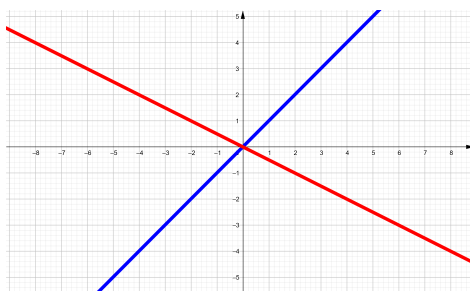

### Solutions of Systems of Diff. Eq. Example 3

**Example:** Find the General Solution of the Linear System of Diff. Eq. given by:

$$\vec{Y}' = \begin{pmatrix} -5 & 2 \\ 1 & -4 \end{pmatrix} \cdot \vec{Y} \quad \text{where } \vec{Y} = \begin{pmatrix} x \\ y \end{pmatrix}$$

### Phase Portrait of Solutions from Example 3

In our last example, we found that the General Solution to:

$$\vec{Y}' = \begin{pmatrix} -5 & 2 \\ 1 & -4 \end{pmatrix} \cdot \vec{Y} \quad \text{where } \vec{Y} = \begin{pmatrix} x \\ y \end{pmatrix}$$

in terms of constants  $c_1$  and  $c_2$  are:  $\vec{Y}(t) = c_1 e^{-3t} \begin{pmatrix} 1 \\ 1 \end{pmatrix} + c_2 e^{-6t} \begin{pmatrix} -2 \\ 1 \end{pmatrix}$

Let's sketch the Phase Portrait using the Gen. Sol. we found.

Straight-line sol's are scalar multiples of e-vects  $\vec{v}_1 = \begin{pmatrix} 1 \\ 1 \end{pmatrix}$  and  $\vec{v}_2 = \begin{pmatrix} -2 \\ 1 \end{pmatrix}$

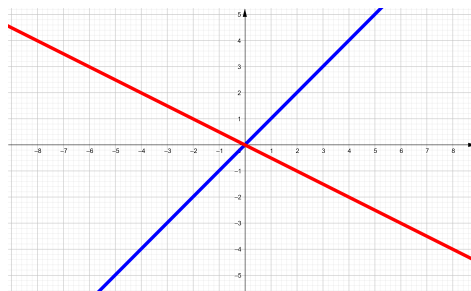

## Equilibrium Solutions of Linear Systems of Diff. Eq.

Earlier in the course, we classified equilibrium solutions of differential equations, and used these classifications to understand the long term behavior of solutions near the equilibrium solutions.

For Linear Systems of Diff. Eq. we'll study and classify equilibrium solutions

We define an *equilibrium solution* of a system of differential equations  $\vec{Y}'(t) = A\vec{Y}(t)$  to be a solution  $\vec{Y}(t)$  such that  $\vec{Y}'(t) = \vec{0}$ .

### Equilibrium Solutions of Linear Systems of Diff. Eq.

The Linear system of Diff. Eq.'s  $\vec{Y}' = A\vec{Y}$ , with  $\det(A) \neq 0$ , has a unique equilibrium solution, which is:  $\vec{Y} = \vec{0}$

We will classify this eq. sol. based on the behavior of nearby solutions.

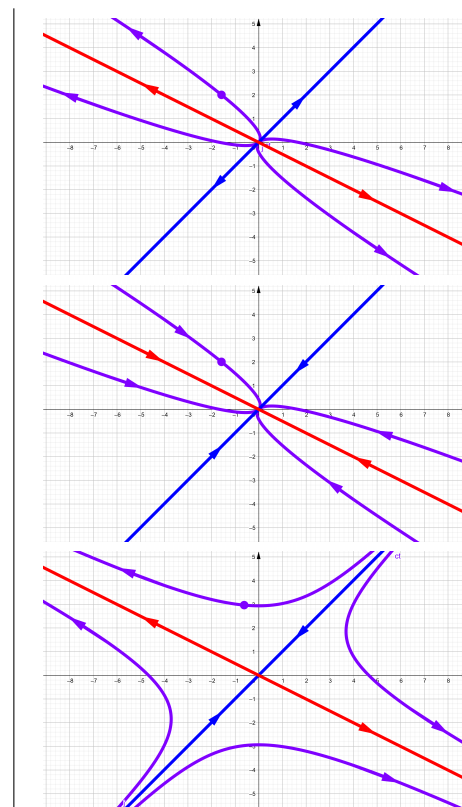

### Example 3 revisited with an Initial Condition

**Example:** Find the solution to the Initial Value Problem given by the diff. eq.:

$$\vec{Y}' = \begin{pmatrix} -5 & 2 \\ 1 & -4 \end{pmatrix} \cdot \vec{Y} \quad \text{where } \vec{Y} = \begin{pmatrix} x \\ y \end{pmatrix}$$

and the Initial Condition  $\vec{Y}(0) = \begin{pmatrix} 7 \\ 1 \end{pmatrix}$

## Solutions of Systems of Diff. Eq. - A Different Example

**Example:** Find the solution to the Linear System of Diff. Eq.:

$$\vec{Y}' = \begin{pmatrix} -2 & -3 \\ 3 & -2 \end{pmatrix} \cdot \vec{Y} \quad \text{where } \vec{Y} = \begin{pmatrix} x \\ y \end{pmatrix}$$





## Solutions of Systems of Diff. Eq. - A Different Example

**Theorem:** If  $\vec{Y}_c(t)$  is a complex solution of the Linear System of Diff. Eq.:

$$\vec{Y}' = A\vec{Y}$$

and if  $\vec{Y}_c(t)$  can be written in its real and imaginary parts:

$$\vec{Y}_c(t) = \vec{Y}_r + i \cdot \vec{Y}_i$$

where  $\vec{Y}_r$  and  $\vec{Y}_i$  are real-valued functions then  $\vec{Y}_r$  and  $\vec{Y}_i$  are, also, solutions.

This can be proved by comparing the real and im. parts of:

$$\left(\vec{Y}_r + i \cdot \vec{Y}_i\right)' = A \cdot \left(\vec{Y}_r + i \cdot \vec{Y}_i\right)$$

$$\vec{Y}(t) = c_1 \vec{Y}_r + c_2 \vec{Y}_i$$

To write  $Y_c(t) = e^{(-2+3i)t} \begin{pmatrix} i \\ 1 \end{pmatrix} = \vec{Y}_r + i \cdot \vec{Y}_i$  in its **real** and **imaginary** parts, we'll start by writing each  $e^{(-2+3i)t}$  and  $\begin{pmatrix} i \\ 1 \end{pmatrix}$  in their **real** and **imaginary** parts

Distributing in  $\vec{Y}_c(t)$ , we get

$$\vec{Y}_c(t) = \left( e^{-2t} \cos(3t) + i e^{-2t} \sin(3t) \right) \left( \begin{pmatrix} 0 \\ 1 \end{pmatrix} + i \begin{pmatrix} 1 \\ 0 \end{pmatrix} \right)$$

Let's review the process of solving a Linear System of Differential Equation

$$\vec{Y}' = \begin{pmatrix} -2 & -3 \\ 3 & -2 \end{pmatrix} \cdot \vec{Y} \quad \text{where } \vec{Y} = \begin{pmatrix} x \\ y \end{pmatrix}$$

We started by finding the characteristic equation:

$$0 = \det(A - \lambda I) = \lambda^2 + 4\lambda + 13$$

### Equilibrium Solutions of Linear Systems of Diff. Eq.

Recall: The Linear system of Diff. Eq.'s  $\vec{Y}' = A\vec{Y}$ , with  $\det(A) \neq 0$ , has a unique equilibrium solution, which is:  $\vec{Y} = \vec{0}$

In cases where the eigenvalues  $\lambda_{1,2} = \gamma \pm i\mu$ , the equilibrium solutions will behave differently than in the cases we saw where  $\lambda_{1,2}$  are real.

If  $\lambda_1 = \gamma + i\mu$  has the eigenvector,  $\vec{v}$ , then we'll have the solution:

$$\vec{Y}_c(t) = e^{(\gamma+i\mu)t} \cdot \vec{v}$$

